



**HD 2003, HD 2003.1
THREE AXIS ULTRASONIC ANEMOMETER**

HD2003 and HD2003.1 are three axis ultrasonic anemometers, they measure the speed and direction of wind, the U-V-W Cartesian components of speed, sound speed and sonic temperature. **The HD2003 allows also to detect temperature and relative humidity of the air and barometric pressure.**

The HD2003 main features are:

- Determination of the anemometric quantities represented in diverse measurement units: wind speed and direction, U-V-W Cartesian components of speed, sound speed, sonic temperature.
- **(HD2003 Model)** additional output quantities: Temperature, Relative Humidity and Pressure.
- 5 analogue voltage or current outputs, with different measuring ranges.
- Up to 12 further analogue current or voltage outputs, with different measuring ranges.
- 4 Serial Communication interfaces: RS232, RS422, Multidrop RS485 and AoXnd
- Configurable output rate of digital output data string.
- Configurable average periods 1÷60sec and 1÷60min. for all output quantities.
- Algorithmic raw data processing and validation, assuring ± 1% precision to anemometric quantities.
- Digital high frequency data acquisition mode with 50Hz data output, or high frequency analogue data acquisition within 5Hz and 20Hz.
- Self-diagnosis with error checking and report.
- Reliability and precision on whole measuring range, no additional calibration required.
- Flexible, easy-to use **demo software**, configurable according to the user's needs through Computer interface.
- User interface for 'Setup' management and software upgrade through RS232 or RS485.
- Automatic alignment to the magnetic North through built in compass.
- No moving part, with reduced maintenance and service costs.
- Rugged and reliable structure, suitable for continuous operation even in severe environmental conditions.
- Low power consumption.
- **(On request) Heaters Option:** built-in heating device of sonic transducers, to prevent ice and snow formation. Assures correct measurements even in presence of sleet or snow.
- **(On request) RS422 Option:** full duplex 4-wire integrated circuit for RS422 communication.

Typical applications:

- Meteorology
- Aviation and Navigation
- Tunnels, Highways
- Climatology
- Sport and winter stations
- Safety in yards
- Construction/Crane safety
- Industrial buildings

Technical specifications

Output quantities

- Anemometric parameters Wind speed and direction, Sound Speed, Sonic Temperature, U-V-W Components
- Meteorological parameters **Model HD2003** Pressure, Temperature, Relative Humidity
- Heading Compass with magnetic Azimuth
- Moving Averages 1÷60 sec. / 1 ÷ 60 min.
- Output rate 1÷3600 sec. or 1/50 sec. (RS232, RS422 or RS485)

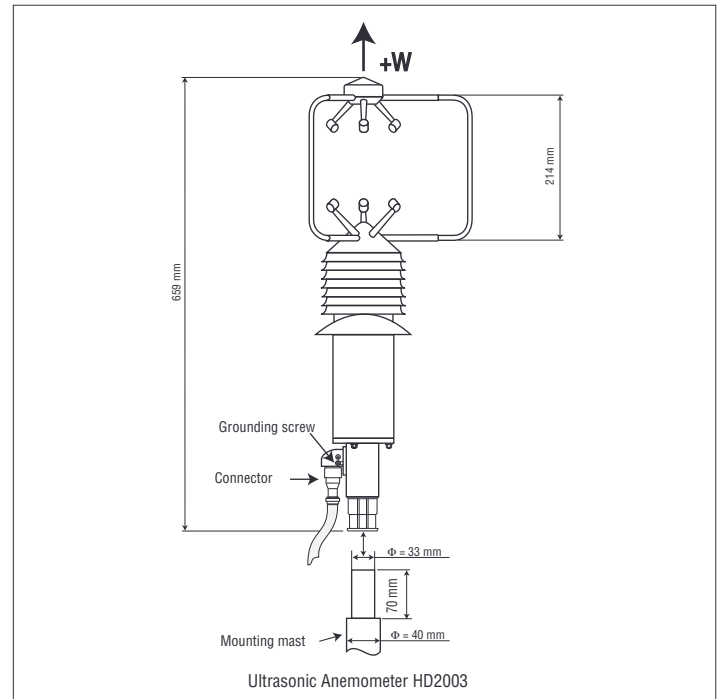

Air speed

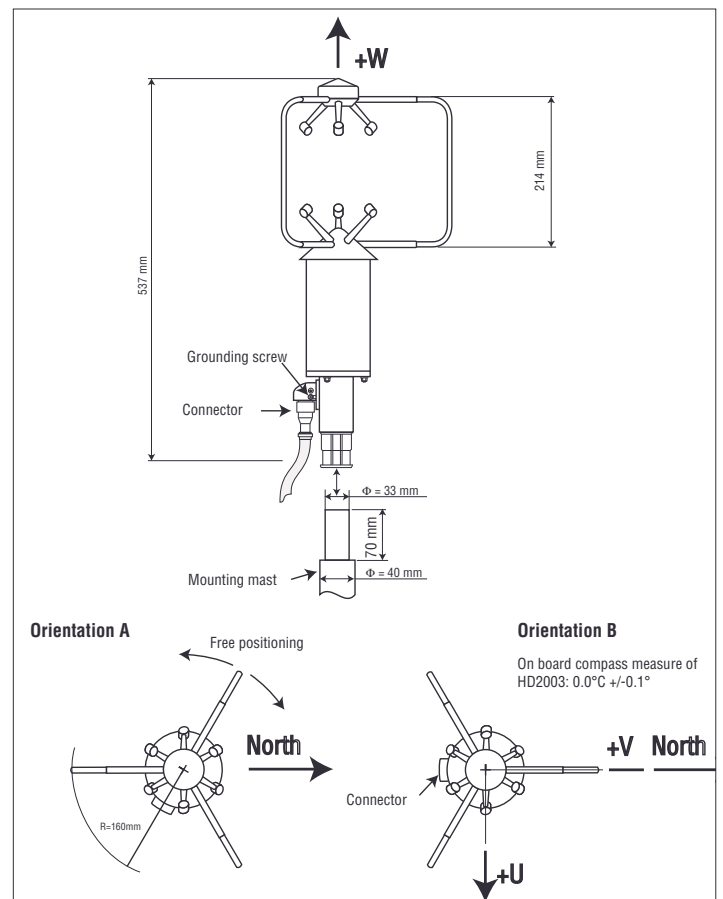

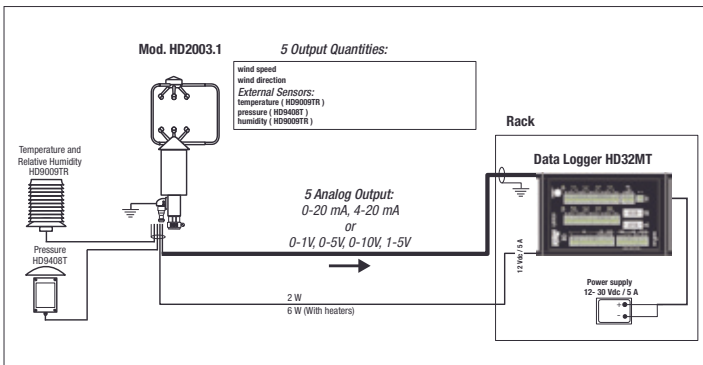
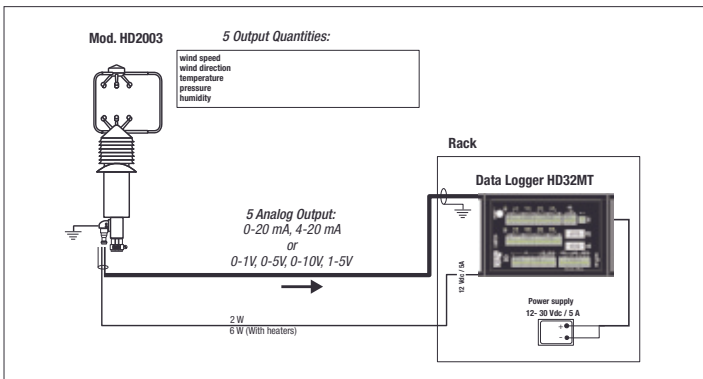
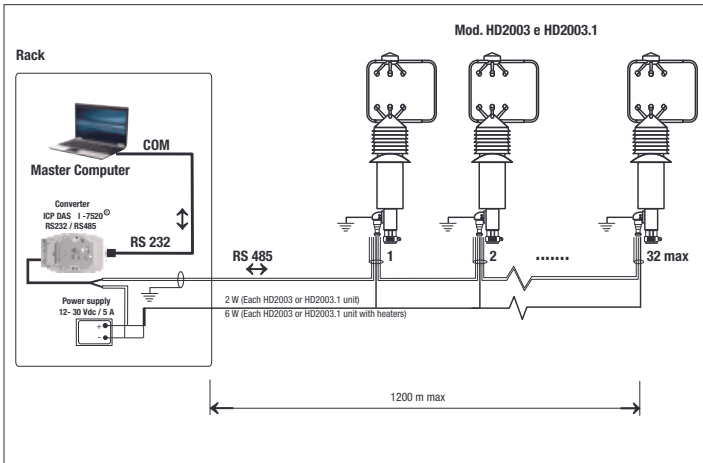
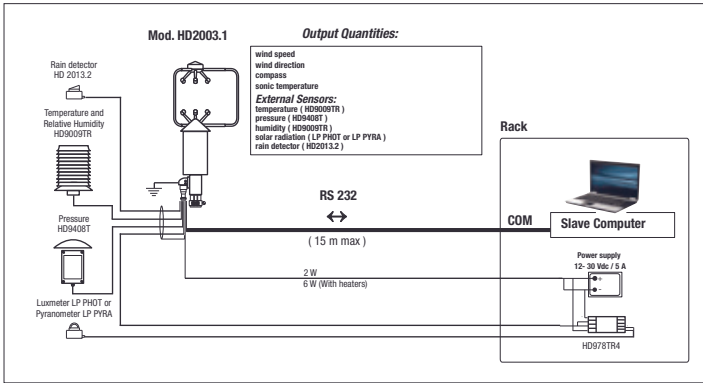
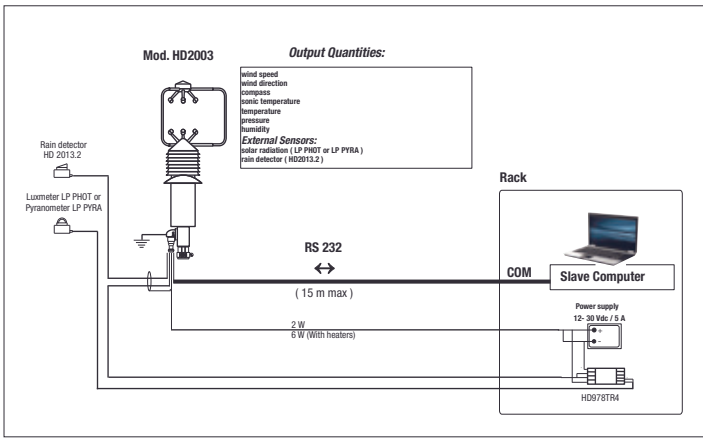

Wind Speed

- Measuring unit m/s, cm/s, km/h, knots, mph
- Range 0÷70 m/s (252 km/h)
- Resolution 0.01 m/s
- Accuracy ± 1% of reading

Wind Direction

- Range Azimuth: 0÷360° Elevation: ± 60°
- Resolution 0.1°
- Accuracy ± 1°

Sound speed

- Range 300 ÷ 380 m/s
- Resolution 0.01 m/s
- Accuracy ± 1% of reading

Sonic Temperature

- Range -40 ÷ 60°C
- Resolution 0.1°C
- Accuracy ± 1°C

Compass

- Range 0 ÷ 360° (measurement in tenths of degree)
- Resolution 0.1°
- Accuracy ± 1°

Digital Outputs

- Communications RS232 and RS422 full duplex, Multidrop RS-485 and AoXand half duplex
- Baud Rate 9600 ÷ 115200 bit/sec.
- Output Rate Normal functioning mode: 1 ÷ 3600 sec Digital high frequency: 1/50 sec

• Measured data

Digital string of anemometric quantities and compass (**Model HD2003**) Pressure, temperature, relative humidity

Analog Outputs

- Number 5, selectable between all available output quantities
- Range 0÷20mA, 4÷20mA, 0÷1V, 0÷5V, 1÷5V, 0÷10V
- Resolution 14 bit max

Extended Analog Outputs (with ICP DAS I-7024 module - on request when placing the order)

- Number max 12, selectable between all available output quantities
- Range 0÷20mA, 4÷20mA, 0÷5V, 0÷10V
- Resolution 14 bit max
- Output rate Normal mode (slow): 1 ÷ 3600s Analogical High frequency (fast): from 5Hz to 20Hz, depending on the baud rate

Power supply

- Range 12 ÷ 30 VDC
- Power <2W (typically 110mA @ 15Vdc) <6W Models with heaters and environment temperature not lower than -10°C

Heaters Option (On request, when placing the order)

Heating with automatic temperature control on sonic transducers, to prevent ice and snow formation.

RS422 Option

Integrated circuit for 4-wire RS422 full duplex communication

Temperature, Relative Humidity, and Pressure Sensors (Model 2003)

Temperature

Pt100 sensor
 Analog output 0÷20mA, 4÷20mA, 0÷1V, 0÷5V, 1÷5V, 0÷10V
 Extended analog output (AoXand): 0÷20mA, 4÷20mA, 0÷5V, 0÷10V
 Range: -40...+ 60°C
 Resolution 0.1°C
 Accuracy ± 0.2°C ± 0.15% of reading

Relative Humidity

Capacitive sensor
 Analog output (0 ÷ 100% RH): 0÷20mA, 4÷20mA, 0÷1V, 0÷5V, 1÷5V, 0÷10V
 Extended analog output (AoXand): 0÷20mA, 4÷20mA, 0÷5V, 0÷10V
 Range: 0 ÷ 100% RH
 Resolution 0.1 % RH
 Accuracy ± 2% RH @ 23°C in the range 5÷90%RH, 2.5% in the remaining range.

Pressure

Piezoresistive sensor
 Analog output: 0÷20mA, 4÷20mA, 0÷1V, 0÷5V, 1÷5V, 0÷10V
 Extended analog output (AoXand): 0÷20mA, 4÷20mA, 0÷5V, 0÷10V
 Range 800 ÷ 1100 mbar (On request: 600 ÷ 1100 mbar)
 Resolution 0.1mbar
 Accuracy ± 0.4mbar @ 20°C
 Thermic effects ± 0.8mbar from -40°C up to +60°C
 Long-term stability < 0.2% f.s. in 6 months @ 20°C

ORDER CODES:

HD2003: Static anemometer for measuring the speed and direction of wind, air temperature, relative humidity and barometric pressure. Wind speed and direction, U-V-W Cartesian Components of speed, sound speed, sonic temperature. Five different analogue voltage or current outputs for different ranges. Communication software for bi-directional links for net connection of different anemometers, interfaces available RS232, RS485, RS422 Different measuring units and average periods are available. Ultrasonic transducers heating as optional. 12..30 Vdc power supply, 120mA consumption at 15Vdc. To be mounted on a mast diam.33mm. Flying connector included.

HD2003R: Transducers heating option for HD 2003 against ice or snow.

HD2003.1: Static anemometer for measuring the speed and direction of wind. Wind speed and direction, U-V-W Cartesian Components of speed, sound speed, sonic temperature. Five different analogue voltage or current outputs for different ranges. Communication software for bi-directional links for net connection of different anemometers, interfaces available RS232, RS485, RS422. Different measuring units and average periods are available. Transducers heating as optional. 12..30 Vdc power supply, 120mA consumption at 15Vdc. To be mounted on a mast diam.33mm. Flying connector included.

HD2003.1R: Transducers heating option for HD 2003.1 against ice or snow.

CP2003/5: 26-pole shielded cable diam. 8mm, length 5m. complete with watertight connector at one side and free at the other end.

CP2003/10: 26-pole shielded cable diam. 8mm, length 10m. complete with watertight connector at one side and free at the other end.

CP2003/C: Watertight 26-pole connector Tyco 62IN- 16A – 16 – 265 – 4 0445

RS2003: Cable with USB connector at one side and watertight connector 26-pole connector at the other end, with 12Vdc power inlet for mains supply.

ICP DAS I-7024CR®: Module for extended analog oputput mode. Indicate how many modules (up to a maximum of 3) and which configuration is required.

ICP DAS I-7520CR®: Module for RS232/RS485 conversion for RS485 Multidrop mode and extended analog output mode.

C.205M: USB/RS232 converter cable, with USB connector at one side and 9-pole male connector at the other end.

HD2003.77: Clamping for mast Ø 40mm

HD2003.77C: 2 crossed sleeves for tube Ø 40mm

HD2003.1.14: Crossed clamping for mast Ø 40mm with 6 inputs Ø 16mm

HD2003.2.17: Support rod for sensors Ø 16mm, length 500mm

HD2003.71K: Mast kit Ø 40mm, height 2m, in two pieces, Ø 33mm tapered tip (HD2003.71, HD2003.72, HD2003.73)

HD2003.74: Clamping with bubble level for Ø 40mm mast with 3 bracing tie rods

HD2003.75: Flange for Ø 40mm mast with grounding rod.

HD2003.75K: Accessories kit for bracing the mast, to fix on the ground (HD2003.80, HD2003.82 - stainless steel strings). 2m fixing diameter.

HD2003.78: Flange plate for Ø 40mm mast to fasten on the floor

HD2003.78K: Accessories kit for bracing the mast, to fasten on the floor (HD2003.81, HD2003.82- stainless steel strings). 2m fixing diameter.

HD2003.79K: Fixing kit to mount pyranometers on clamping Ø 40mm (HD2003.77C - HD2003.79)

HD2003.83: Transverse mast L=150 cm

HD2003.83.1: Transverse mast L=75 cm

HD2003.85K: Fixing kit with adjustable height to mount pyranometers on Ø 40mm mast (HD2003.84 – HD2003.85 – HD2003.79)

Please specify also the following (depending on the selected model):

- **Model HD2003 and HD2003.1:** integrated circuit for 4-wire full duplex RS422 communication.
- **Model HD2003:** if the extension of the analog outputs is required, by additional external sensors with **0÷1V analog output**. In order to linearize their range on the scale **0÷1V**, it is necessary to specify in this case the number of sensors that you intend to employ (max. two), and their physical range.
- **Model HD2003.1:** if the extension of the analog outputs is required by additional external sensors with **0÷1V analog output**. In order to linearize their range on the scale **0÷1V**, it is necessary to specify in this case the number of sensors that you intend to employ (max. five), and their physical range.

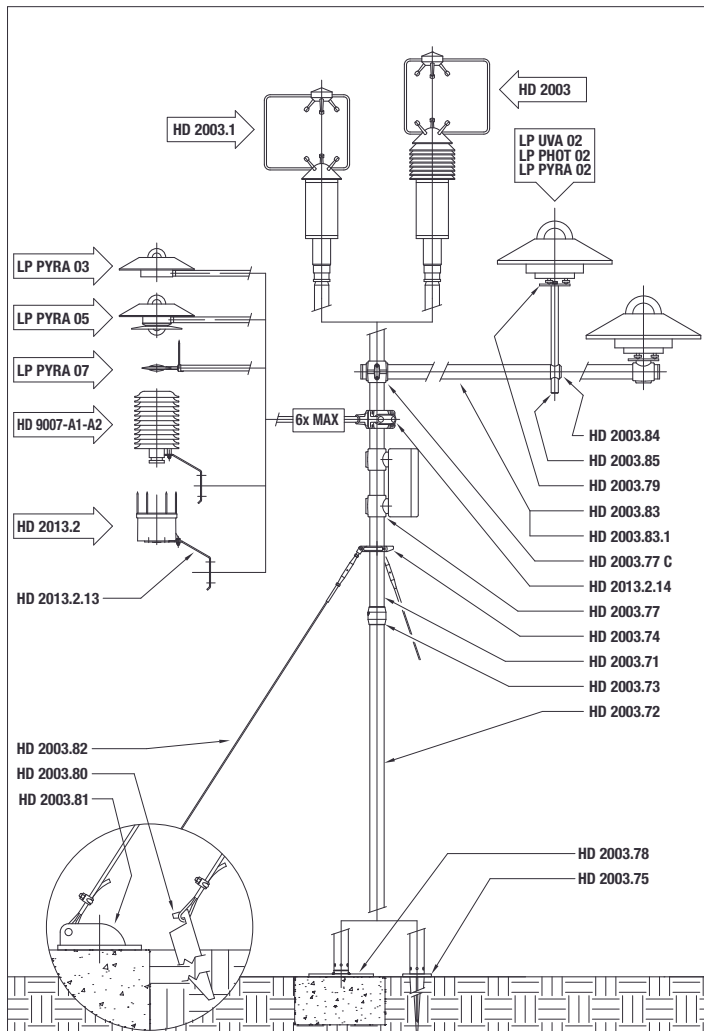

Air speed

