

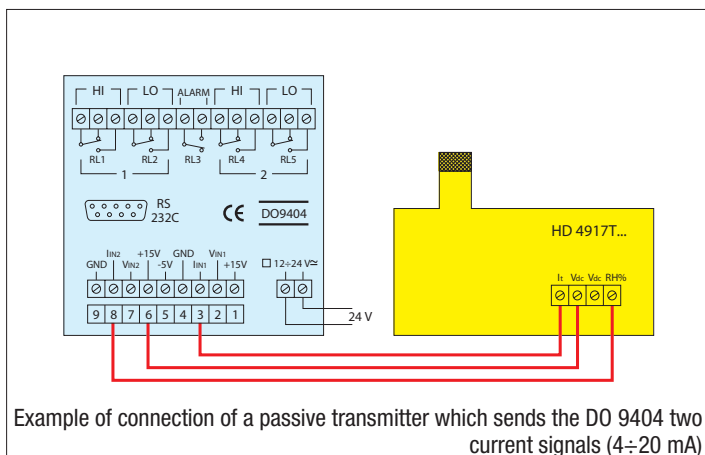

## DO 9404 DUAL REGULATING INDICATOR WITH MICROPROCESSOR CONFIGURABLE WITH TWO VOLTAGE OR CURRENT INPUTS

The dual regulating indicator DO 9404 is a microprocessor-controlled panel instrument with LED 96x96, with thresholds and alarms that may be programmed and configured by the user. In the two input channels it accepts signals coming from two distinct transmitters or from a double transmitter. The transmitters may be passive with 2 wires or active with 3 wires, in voltage 0÷1 V, 0÷5 V, 0÷10 V or current 0÷20 mA; 4÷20 mA.

For both input channels the configuration possibility is always present in the instrument, no extra cards are needed. The choice of configurations for the input signals is made on the keyboard located on the front of the instrument. The DO 9404 is provided with a serial output RS232C, the baud rate may be configured by means of the keyboard, the control is bi-directional and the output connector is a SUB D female 9-pole connector.



Example of connection of a passive transmitter which sends the DO 9404 two current signals (4÷20 mA)

The instrument dimensions are in accordance with DIN 45700, 96x96 mm, depth 120 mm. The operating mode of the DO 9404 is chosen according to the application, configuring the instrument with the keyboard. It is possible to configure the instrument on the field with maximum simplicity to adapt it to changes in the process requirements.

The configuration possibility concerns the inputs, the extent of the scales, the set points, the alarms and the baud rate.

### Applications

A typical application of the DO 9404 is the display and regulation of signals arriving from passive 2-wire or active 3-wire transmitters, of any physical quantity: temperature, humidity, pressure, speed, level, etc. for a wide variety of industrial sectors and automation.

### Characteristics

- Set point may be configured from -9999 to +19999
- Indication with 1/2" red LEDs
- Separate terminal for each channel for voltage input 0÷10 V and current input 0÷20 mA, 4÷20 mA
- On the terminal board an auxiliary power supply is available at -5 Vdc max. 10 mA and +15 Vdc non-stabilized max. 44 mA for the possible feeding of passive 2-wire transmitters
- Instrument accuracy  $\pm 0.1\% \text{ Rdg} \pm 1 \text{ digit}$
- A/D converter resolution: 0.05 mV/digit, 1  $\mu\text{A}$ /digit
- Functions:
  - Two relays with insulated HI LO exchange contact for channel 1: RL1, RL2
  - Two relays with insulated HI LO exchange contact for channel 2: RL4, RL5
  - One relay for the overall maximum and minimum alarms: RL3
  - Resistive 3A/230 Vac relay contacts
- Instrument working temperature: (electronic components) -5°C..50°C
- Power supply: **12÷24  $\pm 10\%$  Vac/Vdc (110÷240Vac/Vdc on request).**

### Error signals

The instrument gives error signals in the following cases:

- OFL:** appears when the SET value is set higher than the high alarm value (maximum).
- OFL:** appears when the SET value is set lower than the low alarm value (minimum).
- E1:** appears when a resolution of the AD converter has been asked for that is higher than what is available: **THE MAXIMUM AD RESOLUTION IS 0.1mV/digit or 2 $\mu\text{A}$ /digit.**
- E2:** appears when there is an analog value at input that is lower or higher than that of the instrument: voltage 0 V..+10 V, current 0-20 mA.
- E3:** appears when the values of the alarm thresholds are inverted.
- E4:** reading/writing mistake on the Eeprom.

### Configuration of the regulating indicator DO 9404

- 1) Supply power to the instrument: 11÷30 Vac; 11÷40 Vdc.
- 2) The dual display indicates OFL on both channels (1 and 2) at the first programming, or values depending on previous programming operations.
- 3) When the **[PROG]** key is pressed, the message FO appears alternately on channel 1 or 2.
- 4) Select which channel (1 or 2) you want to program, for example channel 1.
- 5) Press the **▲** key, the message F1 appears; confirm with the **[ENTER]** key and the symbol A (Ampere = current signal 0÷20 mA, 4÷20 mA) or the symbol U (voltage V = voltage signal 0÷10 V) appears; with the **▲** and **▼** keys, prepare the input for the desired signal, current A or voltage; for example, set A current input, confirm with the **[ENTER]** key, then F1 appears. Press the **▲** key and the message F2 appears.
- 6) Press the key **[ENTER]**, four figures **8888** appear with the decimal point placed at random; using the **▲** and **▼** keys, set the decimal point in the desired position, the possible configurations are:

**8888**  
**8.8**  
**8.88**  
**8.888**

Press the **[ENTER]** key to confirm, then the message F2 appears; press the **▲** key and the message F3 appears.

- 7) Press **[ENTER]**, then using the **▲** and **▼** keys set the start of scale value for channel 1, for example -30.0°C; confirm with **[ENTER]**, the message F3 appears, press the **▲** key and the message F4 appears.

- 8) Press the **[ENTER]** key, then using the **▲** and **▼** keys set the analog value corresponding to the start of scale in voltage or current, depending on the choice made in point 5, for example 4.00 mA; confirm with **[ENTER]**, the message F4 appears, press the **▲** key and the message F5 appears.
- 9) Press **[ENTER]**, then using the **▲** and **▼** keys set the full scale value for channel 1, for example 130.0°C; confirm with **[ENTER]**, the message F5 appears, press the **▲** key and the message F6 appears.
- 10) Press the **[ENTER]** key, then using the **▲** and **▼** keys set the analog value corresponding to the end of scale in voltage or current, depending on the choice made in point 5, for example 20.00 mA; confirm with **[ENTER]**, the message F6 appears, press the **▲** key and the message F7 appears.
- 11) Press the **[ENTER]** key, then using the **▲** and **▼** keys set the SET HI value (closing of contact RL1) for channel 1, for example 0.0°C; confirm with **[ENTER]**, the message F7 appears, press the **▲** key and the message F8 appears.
- 12) Press the **[ENTER]** key, then using the **▲** and **▼** keys set the Reset HI value (opening of contact RL1) for channel 1, for example 10.0°C; confirm with **[ENTER]**, the message F8 appears, press the **▲** key and the message F9 appears.
- 13) Press the **[ENTER]** key, then using the **▲** and **▼** keys set the SET LO value (closing of contact RL2) for channel 1, for example 20.0°C (control of a refrigerating unit, for example); confirm with **[ENTER]**, the message F9 appears, press the **▲** key and the message F10 appears.
- 14) Press the **[ENTER]** key, then using the **▲** and **▼** keys set the Reset LO value (opening of contact RL2) for channel 1, for example 15.0°C (switching off a refrigerating unit, for example); confirm with **[ENTER]**, the message F10 appears, press the **▲** key and the message F11 appears.
- 15) Press the **[ENTER]** key, then using the **▲** and **▼** keys set the low ALARM value for the relay RL3, for example -5.0°C; confirm with **[ENTER]**, the message F11 appears, press the **▲** key and the message F12 appears.
- 16) Press the **[ENTER]** key, then using the **▲** and **▼** keys set the high ALARM value for the relay RL3, for example 25.0°C; confirm with **[ENTER]**, the message F12 appears, press the **▲** key and the message F13 appears.
- 17) Function F13 is used to select the baud rate for serial transmission; press the **[ENTER]** key and a baud rate value appears, then using the **▲** and **▼** keys set the desired rate, choosing one of the following: 300, 600, 1200, 2400, 4800, 9600; the other serial transmission parameters are fixed and cannot be changed; they are:

8 bit  
No Parity  
1 Stop bit

**Note:** the baud rate is the same for both channels. Press **[ENTER]** to confirm, press the **▼** key until F0 appears indicating the end of programming; press the **[ENTER]** key. This operation concludes the programming of channel 1 as described up to this point.

- Programming is the same for both channels, 1 and 2; all that has been described for channel 1 also applies to channel 2.
- The function of the set and reset relays (close contact, open contact), of relays RL1 and RL2 or RL4 and RL5, depends on what the process requires.
- To alter the parameters it is sufficient to enter the program by pressing the **[PROG]** key; when F0 appears, choose the channel in which you want to change the parameter, press the **▲** key until the function that you want to change appears, then make the change with the **▲** and **▼** keys; press **[ENTER]** to confirm, then return to F0 function with the **▼** key, press **[ENTER]** thus returning to normal operation.
- In normal operation, pressing one of the **▲** or **▼** keys passes from the measurement of the physical quantity to the voltage or current value corresponding to the measurement in progress; this applies to both channels. When one of the **▲** or **▼** keys is pressed the instrument returns to normal measuring status.

- The serial interface is active only during normal operation.
- The programming parameters remain in the memory even when the instrument is receiving no power.
- The relays are disconnected during programming.

### Serial interface RS-232C

The DO 9404 is equipped with standard serial interface RS-232C which is available on the SUB D male 9-pin connector. The arrangement of the signals on this connector is as follows;

Pin	Signal	Description
2	TD	Datum transmitted by the DO 9404
3	RD	Datum received by the DO 9404
5	GND	Reference logic ground

The transmission parameters with which the instrument is supplied are:

- baud rate 9600 baud
- parity None
- n. bits 8
- stop bit 1

The data transmission speed may be changed by altering the set-up parameter F13 with the keyboard; the possible baud rates are: 9600, 4800, 1200, 600, 300. The other transmission parameters are fixed.

All the messages reaching and leaving the DO 9404 must be inserted in a "Communication frame" with the following structure:

<Stx><Record><Etx>

where:

- <Stx> Start of text (ASCII 02)
- <Record> constitutes the message
- <Etx> End of text (ASCII 03)

### Host commands

The structure of the command records is as follows:

<Command character><Sub-command><Values>

Where:

- <Command character> is characterized by an alphabetic character indicating the set of commands.
- <Sub-command> is characterized by a character indicating the type of command.
- <Values> is characterized by ASCII characters that depend on the type of command.

The replies provided by the DO 9404 are essentially of two types:

"Information" and "Data".

The former allow information on the status and programming of the DO 9404 to be obtained, as well as the diagnosis of the message received; the latter contain data on the two channels at the moment the request is made.

It is also possible to make use of the serial line for the complete programming of the DO 9404, with the exception of the data transmission speed which may be set only with the keyboard.

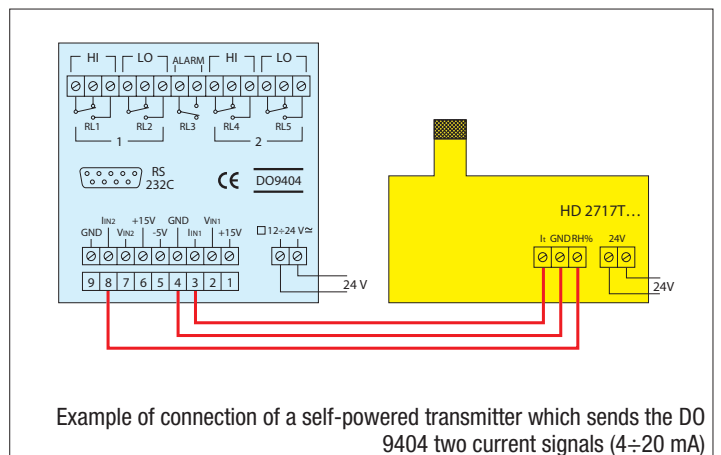
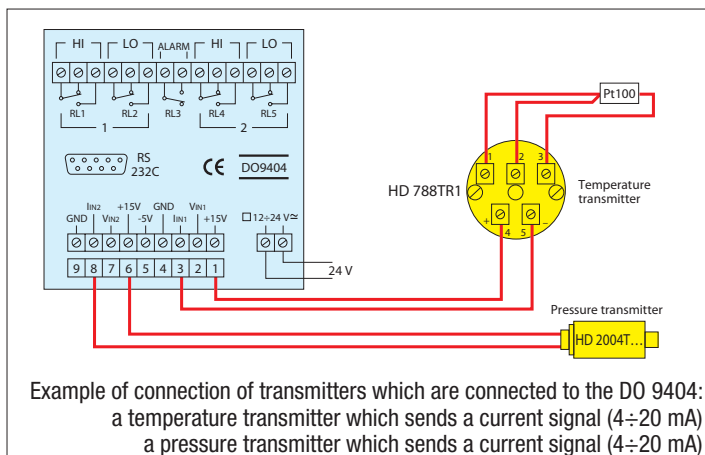

The diagnostic replies of the DO 9404 are composed of the following control characters, sent individually (not inserted in the communication frame):

- ack- Command executed (ASCII 06)
- nak- Incorrect command (ASCII 15H)

#### COMMAND A

Sub-command	Values	Replies
A	Type of terminal	DO 9404
C	Company	DELTA OHM
D	Firmware Version	Vxx Rxx
E	Firmware Date	dd/mm/yy
F	Serial number (rd)	AFxxxxxx
	(wr) xxxxxx	ack/nak

#### COMMAND M

Sub-command	Values	Replies
1	Measure Channel 1	Measure Channel 1
2	Measure Channel 2	Measure Channel 2

#### RESET COMMAND

Sub-command	Values	Replies
RESET	Stx RESET Etx (wr)	ack/nak

#### COMMAND

Sub-command	Values	Replies
1	Set-up Channel 1	Set-up Channel 1
2	Set-up Channel 2	Set-up Channel 2

#### CHANNEL 1

C1F01	x	Input in	V/A	ack/nak
C1F02	x	Point	0/1/2/3	ack/nak
C1F03	xxxx	Start of scale	-9999...19999	ack/nak
C1F04	xxxx	V/I Start of scale	0000...10000 (2000 if I)	ack/nak
C1F05	xxxx	End of scale	-9999...19999	ack/nak
C1F06	xxxx	V/I End of scale	0000...10000 (2000 if I)	ack/nak
C1F07	xxxx	Energ. Relay 1	-9999...19999	ack/nak
C1F08	xxxx	De-energ. Relay 1	-9999...19999	ack/nak
C1F09	xxxx	Energ. Relay 2	-9999...19999	ack/nak
C1F10	xxxx	De-energ. Relay 2	-9999...19999	ack/nak
C1F11	xxxx	Min1 Relay 3	-9999...19999	ack/nak
C1F12	xxxx	Max1 Relay 3	-9999...19999	ack/nak

#### CHANNEL 2

C2F01	x	Input in	V/A	ack/nak
C2F02	x	Point	0/1/2/3	ack/nak
C2F03	xxxx	Start of scale	-9999...19999	ack/nak
C2F04	xxxx	V/I Start of scale	0000...10000 (2000 if I)	ack/nak
C2F05	xxxx	End of scale	-9999...19999	ack/nak
C2F06	xxxx	V/I End of scale	0000...10000 (2000 if I)	ack/nak
C2F07	xxxx	Energ. Relay 4	-9999...19999	ack/nak
C2F08	xxxx	De-energ. Relay 4	-9999...19999	ack/nak
C2F09	xxxx	Energ. Relay 5	-9999...19999	ack/nak
C2F10	xxxx	De-energ. Relay 5	-9999...19999	ack/nak
C2F11	xxxx	Min2 Relay 3	-9999...19999	ack/nak
C2F12	xxxx	Max2 Relay 3	-9999...19999	ack/nak

As regards the command just described, a few remarks must be made:

- There is no command character.
- In the first two cases (Sub-command 1 and 2) the complete set-up of the DO 9404, for Channel 1 and for Channel 2, is made available in the serial line.
- For all the other controls of the type C1F01 etc., the present programming status is supplied for the specific command if only the sequence of the sub-command characters is sent.

Example: StxC1F01Etx Request from Host  
StxC1F01:1Etx Reply

If the sequence of the sub-command characters is followed by a space and then the desired programming value, the programming of the parameter is produced.

Example: StxC1F01 1Etx Command from Host  
ack / nak Reply

**Note:** for programming of the point F03...F12, the value field has fixed length of 5 characters. The first character in the value field may be a space, the minus sign, or the number one.

StxC1F03 1000Etx Request from Host  
ack / nak Reply  
StxC1F03-2000Etx Request from Host  
ack / nak Reply  
StxC1F0512000Etx Request from Host  
ack / nak Reply

