



of the HD2012T... transmitters include:

- Control of illuminance (HD 2021T...) in offices, manufacturing plants and production areas, commercial sites, theatres, museums, sports facilities, roadway lighting, tunnels and nursery-gardening systems.
- Control of solar radiation in the 400nm...1050nm spectral band (HD 2021T1).
- Control of the irradiance emitted by the tanning lamps in the UVA (HD 2021T2) and UVB (HD2021T3) spectral regions, as well as control of the efficiency of filters in devices using high pressure lamps.
- Control of the efficiency of the lamps used in sewage treatment plants, where UVC (HD2021T4) band irradiance has to be constantly monitored.

The series of transmitters HD2021T... is suitable to be installed either indoor and outdoor (Protection: IP66). In case of measurements of extremely intense light sources, the transmitter sensitivity can be reduced upon request. The HD 2021T... series use filters and photodiodes especially studied to adjust spectral response to a specific region of interest.

INSTALLATION OF THE TRANSMITTERS

Once identified the installation location, provide the electric connections inside the transmitter. Unscrew the four screws on the transmitter cover, lift the cover, the inside of the transmitter is as in Figure 1.

The terminal, easily identifiable, is equipped with three terminals with the following letters:

- GND → is the mass to which the power supply and the output signal are referred
- +Vdc → is the head connected to the positive pole (if a DC power supply is used)
- Vlux (output) → is the output of the system to be connected to the positive pole of a multimeter or to a data acquisition system.

The sample below shows the installation of illuminance HD2021T transmitter for monitoring lamps intensity. For this kind of applications, the HD2021T transmitters are generally installed on ceilings, close to the area where illuminance needs to be monitored (figure 2). By means of a reference Luxmeter (ex. HD2102.1 o HD2102.2 with the probe LP471PHOT) previously placed in the operating area, act on the HD2021T potentiometer up to obtain the reference value desired. The output of the HD2021T is suitable to control several adjustable power supply units at the same time.

HD 2021T... TRANSMITTERS FOR ILLUMINANCE AND IRRADIANCE MEASUREMENTS.

The series of transmitters HD 2021T... allow to convert photometric and radiometric quantities, such as illuminance (Lux) and irradiance (W/m²) in the UVA, UVB, UVC spectral regions and in the 400 ... 1050nm voltage signal. The 0 ... 10 V output voltage (0...1V, 0...5V, 4...20mA available upon request for orders of minimum 5 units) is factory calibrated according to the full scale range specified at the time of order. The wide range of applications

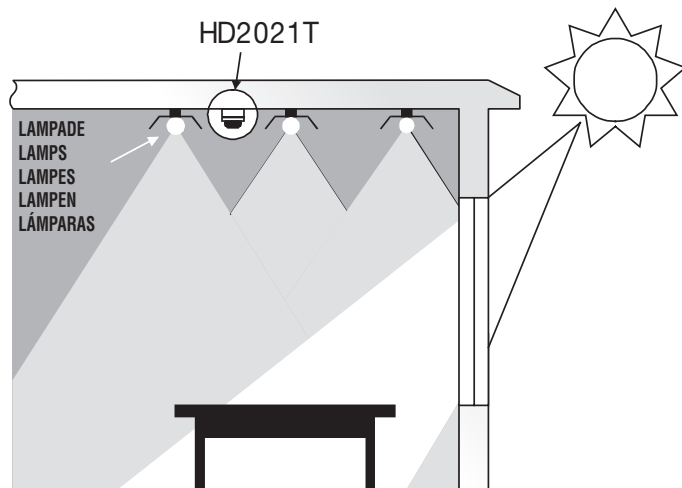

fig. 2

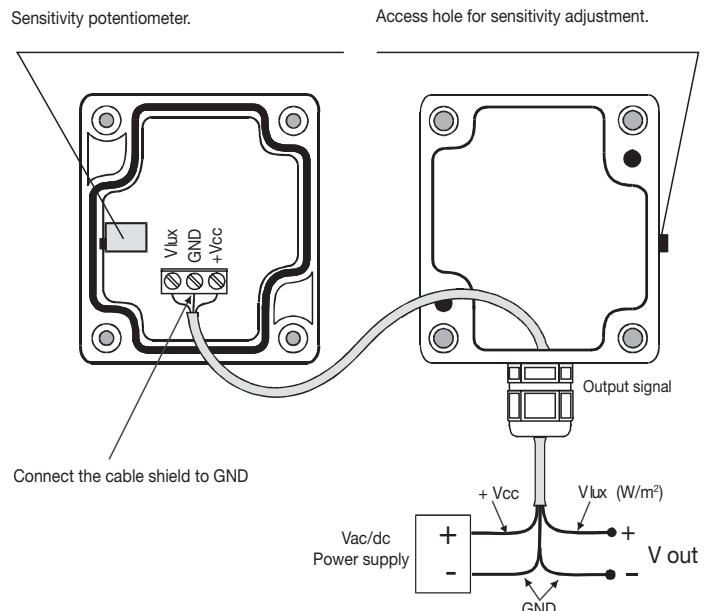
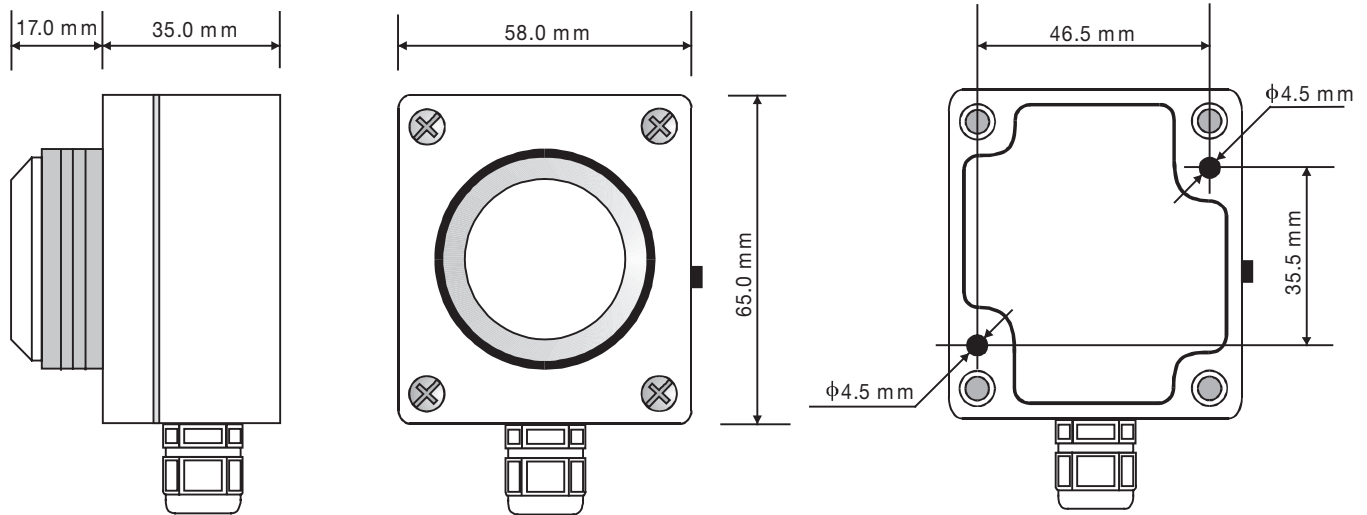

fig. 1

DIMENSIONS:

HD2021T, HD2021T1, HD2021T2, HD2021T3, HD2021T4



TECHNICAL SPECIFICATIONS

	HD2021T	HD2021T1	HD2021T2	HD2021T3	HD2021T4
Sensor	Photodiode Si	Photodiode Si	Photodiode GaP	Photodiode SiC	Photodiode SiC
Spectral range	Curve $V(\lambda)$	450 ... 1050 nm	UVA	UVB	UVC
Measure	Photometric	Radiometric			
Viewing angle	Corrected in accordance with the Cosine law				
Measurement range	see table A - B - C				
	mV/lux	mV/(mW/m ²)	mV/(mW/m ²) peak 360 nm	mV/(mW/m ²) peak 305 nm	mV/(mW/m ²) peak 260 nm
Output signal	0 ... 10 V (0 ... 1 V, 0 ... 5 V minimum order 5 pcs) 4 ... 20mA				
Power supply	16 ... 40 Vdc or 24 Vac, for 0 ... 10 V output 10 ... 40 Vdc or 24 Vac for 0 ... 1 V, 0 ... 5 V output - 10 ... 40 Vdc for 4 ... 20 mA output				
Power consumption	10 mA				
Working temperature	-20 ... +60 °C				
Electrical protection	Protected against polarity inversions				
Maximum dimensions	58 mm x 65 mm x 52 mm				
Degree of protection	IP 66				
Maximum cable length	150 m with output 4...20mA – 10m with the voltage outputs				

Light

ORDERING CODES

* The full scale value has to be selected in the fields A, B, C

MODEL	A	B	C	X
HD 2021 T	0.02...2 klux	0.2...20 klux	2...200klux	Other ranges available upon request for at least 5 pcs per order
HD 2021 T1	0.2...20 W/m ²	2...200 W/m ²	20...2000 W/m ²	
HD 2021 T2	0.2...20 W/m ²	2...200 W/m ²	20...2000 W/m ²	
HD 2021 T3	2...200 W/m ²	20...2000 W/m ²		
HD 2021 T4	2... 200 W/m ²	20...2000 W/m ²		

** For voltage output 0...10V, please indicate: V
 For current output 4...20mA, please indicate: A
 i.e. HD2021TBA: Transmitter for illuminance range 0,2...20klux, Output 4...20mA



**HD 2021T7, HD 2021T6
DEBILITATING LUMINANCE PROBE,
LUMINANCE PROBE**

HD2021T7

The HD2021T7 probe allows converting the photometric quantity “debilitating luminance” into a current (4...20 mA) or a voltage (0...10 V) signal according to the version chosen. If the acquisition station is far from the probe (>50m), it is necessary to use the current output version.

The HD2021T7 transmitter has IP67 protection. In order to grant high accuracy, it is important to keep the surface of the outer lens clean. It is possible to wash them by using only water and standard papers for lens. The transmitter full scale can be chosen (when ordering) between two different values: 2000cd/m² or 20000cd/m². For orders of at least 5 pieces, it is possible to calibrate the scale to a value chosen by the customer.

The probe is used for the control of street lighting, in particular, the measurement of debilitating luminance is essential to determine the *threshold luminance* at the entrance of the tunnels (UNI 11095:2011).

The measurement of debilitating luminance (L_v) consists of three components:

$$L_v = L_{seq} + L_{alm} + L_{par}$$

where,

L_{seq} is the equivalent veiling luminance;

L_{alm} is the atmospheric luminance;

L_{par} is the luminance of the windshield.

The **equivalent veiling luminance (L_{seq})** is measured according to standard UNI11095: 2005 with the probe HD2021T7 as reported in the test report I.N.Ri.M. 08-1199-01. This quantity is measured and defined starting from the subtended angles greater than 1°.

The **atmospheric luminance (L_{alm})** is evaluated with the HD2021T7 probe by measuring the luminance for subtended angles less than 1° (2° total opening) as reported in Tables B and C of the test report.

The contribution of the **luminance of the windshield (L_{par})** is measured directly by inserting the HD2021T7 probe in a protective case. The dialog interface that separates the probe from the external environment simulates the behaviour of the windshield, so the value read by the probe in the container already includes this contribution.

INSTRUMENT TECHNICAL SPECIFICATIONS

Dimensions

(Length x Width x Height) 147mm x 58 mm x 65mm

Figure 1 Dimensions of the HD2021T7 probe

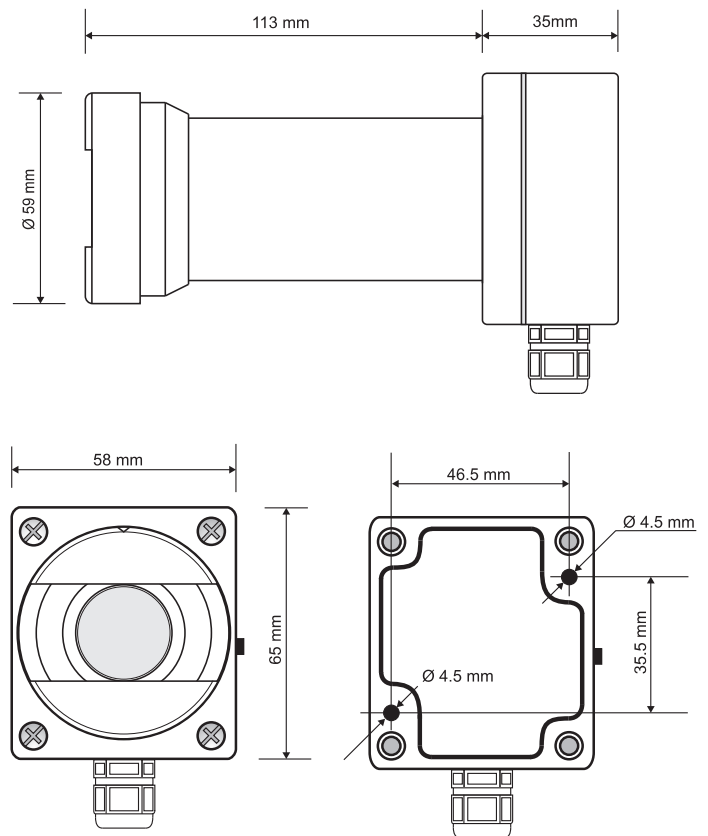

SPECTRAL RESPONSE

The probe uses a silicon photodiode and a set of filters to correct the spectral response curve to make it equal to that of the human eye (photopic response). Figure 2 shows the trend of the relative spectral response according to the wavelength.

$f_1 < 9\%$ according to the standard photopic curve $V(\lambda)$.

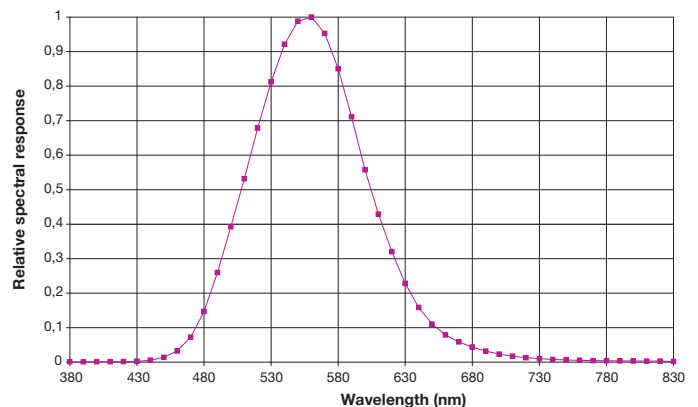

Figure 2. HD2021T7 Relative spectral response

ANGULAR RESPONSE:

The equivalent veiling luminance (L_v) is estimated starting from the following formula:

$$L_v = 10 \sum_{\beta=1^\circ}^{\beta=90^\circ} \frac{L(\beta) \cdot \cos(\beta)}{\beta \cdot (\beta + 1.5)} \cdot \Omega \quad \mathbf{A}$$

where:

- $L(\beta)$ is the luminance of a source of disturbance measured at an angle β ,
- β is the angle between the pointing direction of the object to be watched and the source of interference,
- Ω is the solid angle

Figure 3 shows the sensitivity as a function of the angle of the probe. In the standard CIE88:2004 the equivalent veiling luminance is calculated by considering the contributions up to angles of 28.4°. By using DeltaOhm probe HD 2021T7 it is possible to evaluate contributions to greater angles (up to 40°).

Figure 3. HD2021T7 Relative angular response

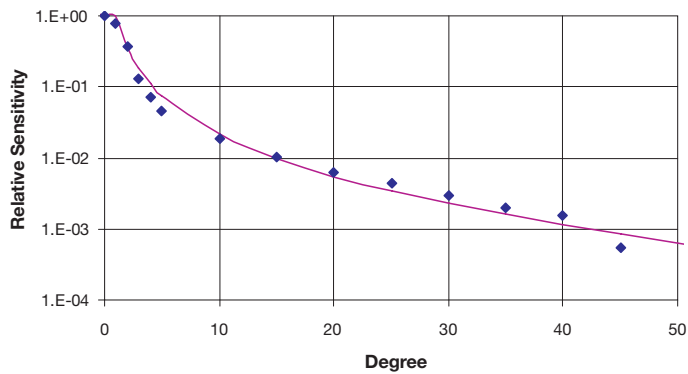

For angles less than 1° as shown in fig.3 the probe measures the luminance necessary for the proper calculation of the contributions of the atmospheric luminance and the luminance of windshield.

WORKING TEMPERATURE

The probe can work in a temperature range from -20° to +60° C. If the probe is placed in watertight containers, take care that there is no fogging or condensation on the window towards which the probe is overlooking. In this case the reading of the equivalent veiling luminance would be altered by systematic errors.

CALIBRATION

The calibration of the probe HD2021T7 is carried out by measuring the luminance on the output port of an integrating sphere with a known luminance. If requested, the uncertainty of the calibration of the probe with fixed full scale is 10% (confidence level of 95%).

TRANSMITTER INSTALLATION

The installation of the probe for the evaluation of the *threshold luminance* at the entrance of tunnels should be performed in compliance with the standard UNI 11095.

In order to connect the transmitter, it is necessary to lift the lid (by unscrewing the four locking screws). For the 4...20mA version, please refer to Figure 5, while the version 0...10 V is referred to Figure 4.

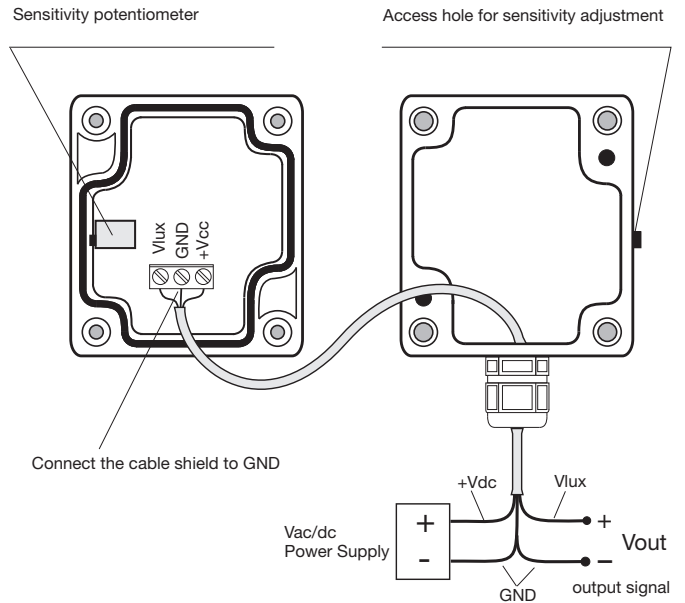

Figure 4. Connection diagram for HD2021T... with voltage output

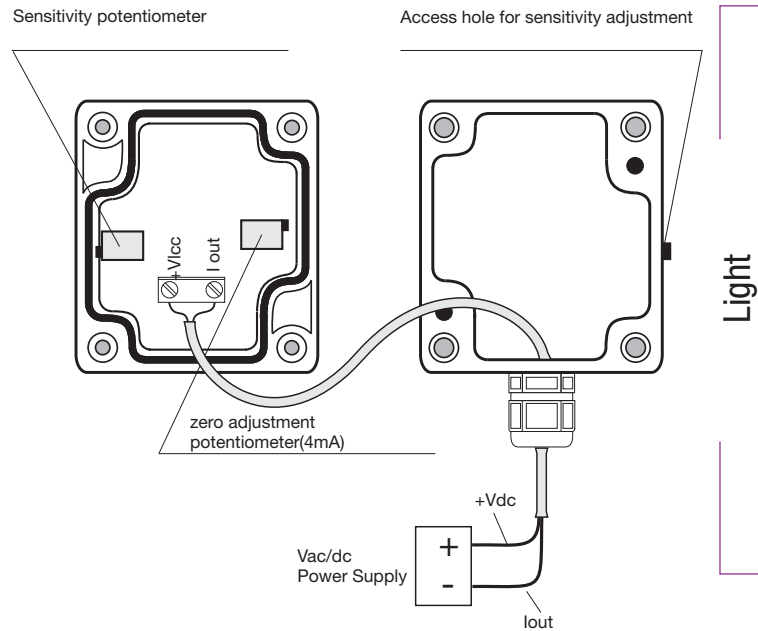

Figure 5. Connection diagram for HD2021T... with current output

ORDERING CODES:

	Output	Measurement range	Power supply	Spectral response
HD2021T7A.V	0...10 V	0...2000 cd/m ²	16...40 Vac/dc	V(λ)
HD2021T7B.V		0...20 kcd/m ²		
HD2021T7X.V		Upon request *		
HD2021T7A.A	4...20 mA	0...2000 cd/m ²		
HD2021T7B.A		0...20 kcd/m ²		
HD2021T7X.A		Upon request *		

*minimum order 5 pcs

HD2021T6

The probe HD 2021T6 allows converting a photometric quantity Luminance (cd/m^2) into a current (4...20 mA) or voltage (0...10 V) signal according to the version chosen. If the acquisition station is far from the probe (>50m), the current version is required.

The protection degree of the transmitter HD2021T6 is IP67. In order to ensure correct measurements, the outer surface of the lens must be kept clean. If necessary, clean the lens with water and lens cleaning paper.

At the order time, it is possible to choose the transmitter sensitivity among three previously set values: $2 \text{ kcd}/\text{m}^2$, $20 \text{ kcd}/\text{m}^2$ or $200 \text{ kcd}/\text{m}^2$. For orders of quantities over 5 pieces, the full scale can be customized.

The probe is used for road lighting control. In particular, the measurement of luminance at a 20° angle (L_{20}) is necessary to estimate *threshold luminance* at tunnel entrances (CIE standard 88:2004. This standard foresees the measurement of debilitating luminance in future).

Moreover, the probe can be used for calculating vertical illuminance (E_v) as prescribed in the above-mentioned standard.

Finally, the probe can be used for any application where the measurement of luminance is required, for example projector screens, diaphanoscopes etc.

Instrument technical specifications

Dimensions

(Length x Width x Height) 145mm x 58 mm x 65mm

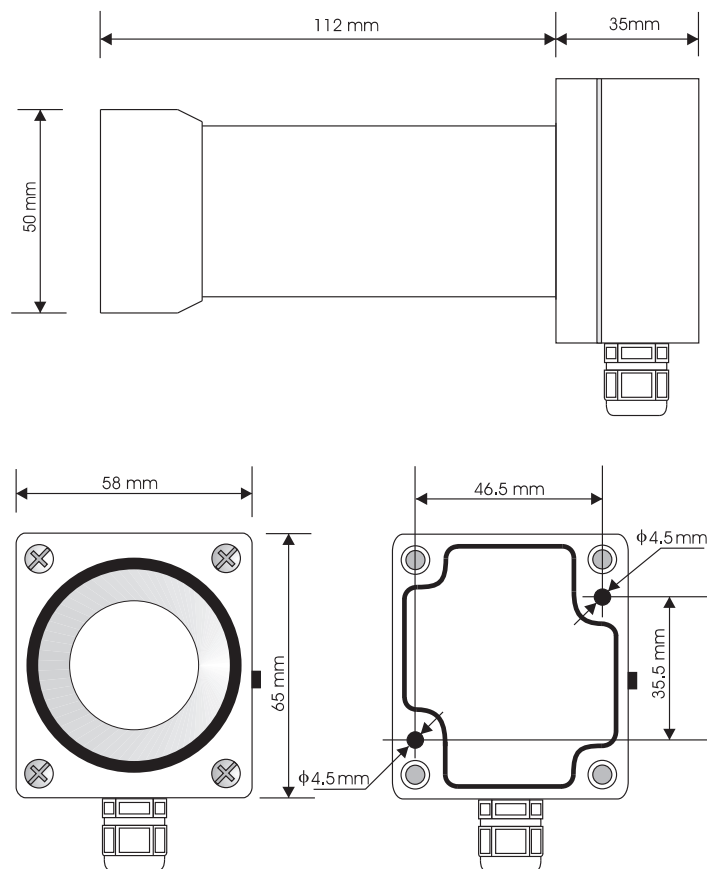

Figure 1. HD2021T6 probe dimensions

Spectral Response

The probe is equipped with a silicon photodiode and a series of filters to correct the spectral response curve and make it equal to that of the human eye (photopic response). Figure 2 shows the trend of the relative spectral response depending on the wavelength.

$f'_1 < 9\%$ according to the standard photopic curve $V(\lambda)$.

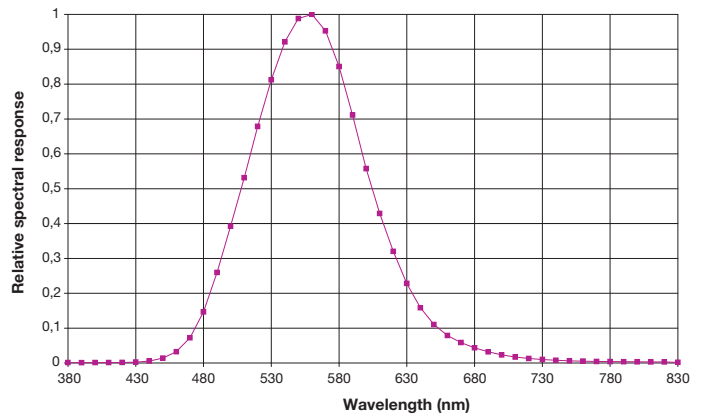

Figure 2. HD2021T6 probe relative spectral response

FIELD OF VIEW

The total field of view of HD2021T6 probe is 20° .

WORKING TEMPERATURE

The probe can work in a temperature range from -20° to $+60^\circ$ C. If the probe is placed in watertight containers, take care that there is no fogging or condensation on the window towards which the probe is overlooking. In this case the reading of the equivalent veiling luminance would be altered by systematic errors.

CALIBRATION

The calibration of the probe HD2021T6 is carried out by measuring the luminance on the output port of an integrating sphere with a known luminance. If requested, the uncertainty of the calibration of the probe with fixed full scale is 5% (confidence level of 95%).

TRANSMITTER INSTALLATION

The installation of the probe for the evaluation of the *threshold luminance* at the entrance to the galleries has to be performed according to standard CIE 88:2004.

In order to connect the transmitter, it is necessary to lift the lid (by unscrewing the four locking screws). For the 4...20mA version refer to Figure 5, while for the version 0...10 V refer to Figure 4 of HD2021T7.

ORDERING CODES:

Model	Output	Measurement range	Power supply	Spectral Response
HD2021T6A.V	0...10 V	0...2000 cd/m^2	16...40 Vac/dc	$V(\lambda)$
HD2021T6B.V		0...20 kcd/m^2		
HD2021T6C.V		0...200 kcd/m^2		
HD2021T6X.V	Upon request *			
HD2021T6A.A	4...20 mA	0...2000 cd/m^2		
HD2021T6B.A		0...20 kcd/m^2		
HD2021T6C.A		0...200 kcd/m^2		
HD2021T6X.A		Upon request *		

*minimum order 5 pieces