

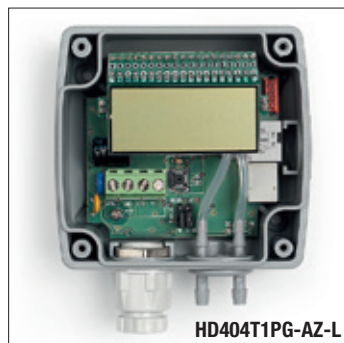

HD 404T VERY LOW PRESSURE TRANSMITTER

The series of HD404T transmitters is able to measure relative pressures with reference to the atmosphere or differential in the range from 50 to 1000 Pa (0.2" H₂O to 5" H₂O). HD404T transmitters use a silicon "micromachined" type sensor compensated in temperature that has an excellent linearity, repeatability and stability over time. The output signal from the sensor is amplified and converted into a standard analogical output in current (4...20mA) and in one in voltage (0...10V), which, then, can be transmitted over long distances with a high immunity to noise.

In each model it's possible to choose, via a dip switch, between two measurement ranges in order to select the optimal scale for each application. Usually the low pressure transmitters are susceptible to the guidance by which they are mounted. In HD404T series there is available a special auto-zero circuit, which periodically equalize the differential pressure at the input sensor and corrects the offset; the transmitters, provided with this circuit, are insensitive to the mounting position. In addition, the circuit compensates autozero aging and the deviation of the zero of the sensor to temperature changes: virtually eliminates maintenance.



It's available the (L) "display" option, in which the pressure is visualized on a display with 4 digits in the selected measurement unit.

The (SR) "square root" is especially useful if the transmitter is connected to a Pitot or Darcy tube, as the output is directly proportional to the speed of airflow. The SR version with L option also allows to display, in addition to the pressure measured, the speed of airflow calculated. The SR version is configurable by the user by connecting the transmitter to a PC and sending serial commands via a standard communication software. It is possible to set the coefficient of the Pitot or Darcy tube used, the parameters for the calculation of the speed (airflow temperature, barometric pressure, differential static pressure in the duct), the speed unit of measurement (m/s or ft/s) and the speed full scale for the analog output. The transmitters are ready to use and are supplied calibrated at 3 points by the manufacturer.

Typical applications for HD404T series are clean room monitoring, filters' control, flow measures (matched with the Pitot tube), the air conditioning control and the ventilation one.

TECHNICAL COMMON FEATURES @ 20°C AND 24VDC

Sensor	Piezoresistive
Measurement range	from 0...50 Pa (0...0,2" H ₂ O) to 0...1000 Pa (0...4" H ₂ O) relative and differential (see table) For the SR models, the speed measurement ranges depend on the tube constant, the temperature and the pressure (see table)
Output signal	0...10 Vdc R _i > 10 kΩ and 4...20 mA R _i < 500 Ω
Accuracy	It depends on the model (see table)
Response time	1 s (fast) or 4 s (slow) selectable through jumper
Over-pressure limit	25 kPa
Compatible media	Only air and non-aggressive gases
Power supply	24 Vac ± 10% or 16...40 Vdc
Absorption	< 1 W
Pressure fit	With Ø 5 mm flexible tube
Electrical connections	Terminal board with screws, max 1.5 mm ² , PG9 conduit for input cable
Working conditions	-10...+60 °C (-5...+50 °C for models with auto-zero AZ), 0...95% RH
Storage temperature	-20...+70 °C
Case sizes	80 x 84 x 44 mm
Degree of protection	IP67

INSTALLATION

In all the models, the sensor and the electronic are contained in a sturdy plastic case with an IP67 protection degree. Opening the lid are available 3 mm diameter holes that let you set the base of the transmitter directly to a panel or a wall.

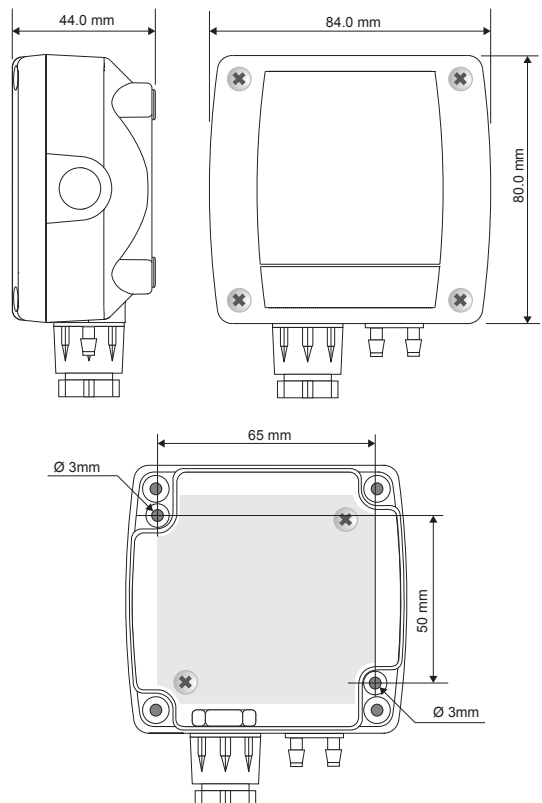

HD404T can be mounted in any position, but typically on a vertical wall with the pressure inlets facing downwards. The gap from zero due to the mounting position can be compensated by using CAL ZERO button. The procedure to follow for manual calibration of zero is the following one:

- Make sure that the transmitter is powered by at least 1 hour;
- Disconnect both tubes from the + and – pressure inlets;
- Press CAL ZERO button until the red LED starts to flash;
- When the red led turns off, the zero procedure is completed and you can reconnect the tubes to pressure fits.

We suggest you to perform the auto-zero procedure at least once a year under normal working conditions.

In models with auto-zero circuit (AZ option), this procedure is regularly performed every 15 minutes without disconnecting the hoses from pressure taps. During the reset, which takes about 4 seconds, the analogical outputs and the display will remain frozen at the measured value. Models with auto-zero have virtually no need for maintenance.

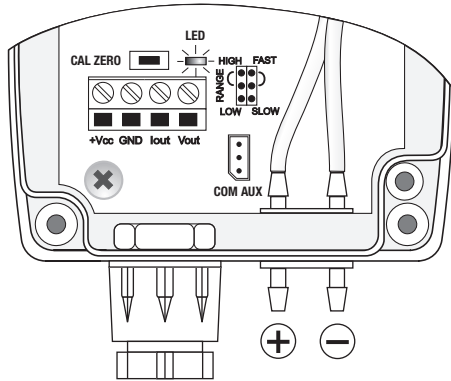

CAL ZERO button and configuration jumpers

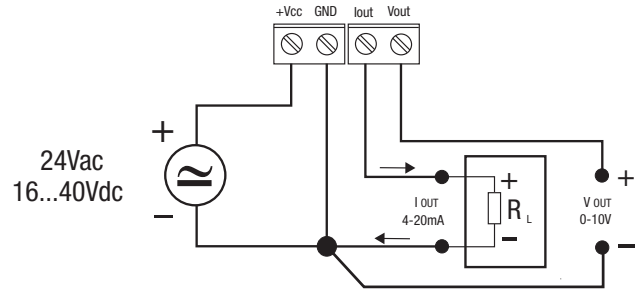

Electrical connections

CONFIGURATION

Setting the output range: the RANGE jumper allows you to choose one of this output ranges: with LOW you choose the low range, with HIGH the extended range.

Response time setting: the FAST SLOW jumper lets you choose the response time of the transmitter: in FAST position the measurement is integrated over 1 s, while in SLOW position is integrated over 4 s. SLOW position is recommended if there are conditions of turbulence or disruption of air flow.

Setting of the parameters in the SR versions: the transmitters are preset by the factory. To change the settings, proceed as follows:

- Connect the transmitter COM AUX serial output to the PC RS232 (through the **RS27** cable) or USB (through the **CP27** cable) port. If the CP27 cable is used, install in the PC the related USB drivers.
- In the PC, run a serial communication software (e.g. Hyperterminal), set the baud rate to 115200 and the communication parameters to 8N2.
- To change the display configuration (commands O3E, O3D, O4E, O4D, O5E, O5D) it is necessary to send the CAL START command to enter the configuration mode. It is not necessary to send the CAL START command to change the parameters related to the speed measurement (tube coefficient, temperature, pressure, full scale for the analog output).
- Send the commands in the following table to set or read the configuration parameters of the transmitter:

SUMMARY TABLE OF MODELS AND ACCURACY

MODEL	RANGE		ACCURACY %F.S. RANGE HIGH (0...+50 °C)	LONG TERM STABILITY (1 YEAR)	
	LOW	HIGH		AZ	NO AZ
	Pa				
HD404T1PG(-L-SR)	0...50 Pa	0...100 Pa	±3%	≤±1Pa	
HD404T2PG(-L-SR)	0...100 Pa	0...250 Pa	±1,5%	≤±1Pa	
HD404T3PG(-AZ-L-SR)	0...250 Pa	0...500 Pa	±1%	≤±1Pa	≤±8Pa
HD404T4PG(-AZ-L-SR)	0...500 Pa	0...1000 Pa	±1%	≤±1Pa	≤±8Pa
HD404T1PD(-AZ-L)	-50...+50 Pa	-100...+100 Pa	±1,5%	≤±1Pa	
HD404T2PD(-AZ-L)	-100...+100 Pa	-250...+250 Pa	±1%	≤±1Pa	
HD404T3PD(-AZ-L)	-250...+250 Pa	-500...+500 Pa	±1%	≤±1Pa	≤±8Pa
HD404T4PD(-AZ-L)	-500...+500 Pa	-1000...+1000 Pa	±1%	≤±1Pa	≤±8Pa
	mmH ₂ O				
HD404T1MG(-AZ-L-SR)	0...5 mmH ₂ O	0...10 mmH ₂ O	±3%	≤±0,1 mmH ₂ O	
HD404T2MG(-AZ-L-SR)	0...10 mmH ₂ O	0...25 mmH ₂ O	±1,5%	≤±0,1 mmH ₂ O	
HD404T3MG(-AZ-L-SR)	0...25 mmH ₂ O	0...50 mmH ₂ O	±1%	≤±0,1 mmH ₂ O	≤±0,8 mmH ₂ O
HD404T4MG(-AZ-L-SR)	0...50 mmH ₂ O	0...100 mmH ₂ O	±1%	≤±0,1 mmH ₂ O	≤±0,8 mmH ₂ O
HD404T1MD(-AZ-L)	-5...+5 mmH ₂ O	-10...+10 mmH ₂ O	±1,5%	≤±0,1 mmH ₂ O	
HD404T2MD(-AZ-L)	-10...+10 mmH ₂ O	-25...+25 mmH ₂ O	±1%	≤±0,1 mmH ₂ O	
HD404T3MD(-AZ-L)	-25...+25 mmH ₂ O	-50...+50 mmH ₂ O	±1%	≤±0,1 mmH ₂ O	≤±0,8 mmH ₂ O
HD404T4MD(-AZ-L)	-50...+50 mmH ₂ O	-100...+100 mmH ₂ O	±1%	≤±0,1 mmH ₂ O	≤±0,8 mmH ₂ O
	inchH ₂ O				
HD404T1IG(-AZ-L-SR)	0...0.2 inchH ₂ O	0...0.4 inchH ₂ O	±3%	≤±0,04 inchH ₂ O	
HD404T2IG(-AZ-L-SR)	0...0.4 inchH ₂ O	0...1 inchH ₂ O	±1,5%	≤±0,04 inchH ₂ O	
HD404T3IG(-AZ-L-SR)	0...1 inchH ₂ O	0...2 inchH ₂ O	±1%	≤±0,04 inchH ₂ O	≤±0,04 inchH ₂ O
HD404T4IG(-AZ-L-SR)	0...2 inchH ₂ O	0...4 inchH ₂ O	±1%	≤±0,04 inchH ₂ O	≤±0,04 inchH ₂ O
HD404T1ID(-AZ-L)	-0.2...0.2 inchH ₂ O	-0.4...0.4 inchH ₂ O	±1,5%	≤±0,04 inchH ₂ O	
HD404T2ID(-AZ-L)	-0.4...0.4 inchH ₂ O	-1...+1 inchH ₂ O	±1%	≤±0,04 inchH ₂ O	
HD404T3ID(-AZ-L)	-1...+1 inchH ₂ O	-2...+2 inchH ₂ O	±1%	≤±0,04 inchH ₂ O	≤±0,04 inchH ₂ O
HD404T4ID(-AZ-L)	-2...+2 inchH ₂ O	-4...+4 inchH ₂ O	±1%	≤±0,04 inchH ₂ O	≤±0,04 inchH ₂ O

Command	Reply	Description
03E	&	Shows alternately speed and pressure on display
03D	&	Disables the alternating display of speed and pressure
04E	&	Automatic change of speed resolution on display (0,1 or 0,01) depending on the measured value ⁽¹⁾
04D	&	Fixed centesimal speed resolution on display ⁽¹⁾
05E	&	Sets ft/s as speed unit of measurement on display <i>Note: the symbol ft/s does not appear on display</i>
05D	&	Sets m/s as speed unit of measurement on display (default)
CK n.n...	&	Sets the Pitot or Darcy tube coefficient to the value n.n... The value must be between 0.6 and 1.2 (default = 1.0)
RK	n.nnnnnl	Reads the value of the tube coefficient set in the transmitter
CB nnnn. nn...	&	Sets the barometric pressure to the value nnnn.nn... mbar The value must be between 500 and 1500 mbar (default = 1013.25 mbar)
RB	nnnn.nnnl	Reads the value of the barometric pressure in mbar set in the transmitter
CT n...	&	Sets the airflow temperature in tenths of °C (default = 160 → 16.0 °C) The value must be between -999 (→ -99.9 °C) and 2000 (→ 200.0 °C)
RT	n...l	Reads the value of the temperature, in tenths of °C, set in the transmitter
CP nnnn...	&	Sets the differential static pressure ⁽²⁾ in mbar (default = 0)
RP	nnnn...l	Reads the value of the differential static pressure ⁽²⁾ set in the transmitter
CS nnnn	&	Sets the full scale speed, in hundredths of m/s, for the analog output (default = see table). The max settable value is 10000 (→ 100.00 m/s)
RS	nn.nnl	Reads the speed full scale value, in m/s, for the analog output
SV	nn.nnl	Prints the max measurable speed as a function of the transmitter full scale pressure and values set for the parameters. The value is in the speed unit of measurement set in the transmitter.

⁽¹⁾ The speed is calculated from the pressure measure through a quadratic relationship. For this reason, the speed resolution is lower for low pressure values measured, and the change of the speed measurement on the display appears rather discontinuous if the fixed centesimal resolution is used. If a more uniform speed change on display is desired, enable the automatic speed resolution change as a function of the measured value.

⁽²⁾ The differential static pressure is equal to the difference between the absolute static pressure inside the duct and the barometric pressure. The differential static pressure is zero if the duct is open (in contact with the atmosphere), while it can be different from zero in case of closed ducts.

To exit the configuration mode after sending the CAL START command, send the CAL END command (the transmitter automatically exits the configuration mode after 5 minutes from the last command sent).

DISPLAY

Models with L suffix are provided with a LCD display with 4 digits.

Pressure display resolution:

50 - 100 - 250 - 500 Pa	→	0.5 Pa
1000 Pa	→	1 Pa
5 - 10 - 25 - 50 mmH ₂ O	→	0.05 mmH ₂ O
100 mmH ₂ O	→	0.1 mmH ₂ O
0.2 - 0.4 - 1 - 2 - 4 inchH ₂ O	→	0.002 inchH ₂ O

Speed display resolution in the SR models: for all the ranges, the speed resolution can be centesimal fixed or with automatic change from decimal to centesimal as a function of the measured value. The selection between the two options is made via the serial commands 04E and 04D.

Error reporting:

Undr	→	it appears if the measured value is smaller than the minimum value that can be measured
OvEr	→	it appears if the measured value exceeds the maximum value that can be measured
CAL Error	→	it appears when the zero calibration is finished if the maximum offset value that can be corrected is exceeded.

SPEED FULL SCALE IN THE SR MODELS

In the SR models, the maximum speed measurable depends on the coefficient of the tube used, the temperature, the barometric pressure and the differential static pressure set in the transmitter. The serial command SV allows to read the maximum speed measurable as a function of the parameters setting. The following table shows the maximum speed measurable by the various models with the values of the parameters preset by the factory: tube coefficient **K = 1.0**, temperature **T = 16.0 °C**, barometric pressure **Patm = 1013.25 mbar**, differential static pressure **Ps = 0**.

MODEL	MAX SPEED MEASURABLE (@ K = 1, T = 16°C, Patm = 1013.25 mbar, Ps = 0)		DEFAULT FULL SCALE FOR THE ANALOG OUTPUT (changeable with the CS command)
	LOW	HIGH	
HD404T1PG-AZ(-L)-SR	9,06 m/s	12,82 m/s	10 m/s
HD404T2PG-AZ(-L)-SR	12,82 m/s	20,27 m/s	20 m/s
HD404T3PG(-AZ-L)-SR	20,27 m/s	28,67 m/s	25 m/s
HD404T4PG(-AZ-L)-SR	28,67 m/s	40,55 m/s	40 m/s
HD404T1MG-AZ(-L)-SR	8,98 m/s	12,70 m/s	10 m/s
HD404T2MG-AZ(-L)-SR	12,70 m/s	20,08 m/s	20 m/s
HD404T3MG(-AZ-L)-SR	20,08 m/s	28,39 m/s	25 m/s
HD404T4MG(-AZ-L)-SR	28,39 m/s	40,16 m/s	40 m/s
HD404T1IG-AZ(-L)-SR	9,05 m/s	12,80 m/s	10 m/s
HD404T2IG-AZ(-L)-SR	12,80 m/s	20,24 m/s	20 m/s
HD404T3IG(-AZ-L)-SR	20,24 m/s	28,62 m/s	25 m/s
HD404T4IG(-AZ-L)-SR	28,62 m/s	40,48 m/s	40 m/s

The following graphs show the change of the maximum measurable speed value (normalized to 1 for $T=16.0\text{ }^{\circ}\text{C}$ and $\text{Patm}=1013.25\text{ mbar}$) with the change of the temperature and barometric pressure.

ACCESSORIES

Supplied:

- N°1 piece of $\text{Ø}3.2/\text{Ø}6.4$ silicone tube 2m long
- N°2 HD434T.5 plastic fittings

Under request:

HD3719: Flow offtake for square or cylindrical channel. Two pieces of $\text{Ø}3.2/\text{Ø}6.4$ tube 1m long.

HD3721: Flow offtake for plastic material cylindrical channel. Two pieces of $\text{Ø}3.2/\text{Ø}6.4$ tube 1m long.

RS27: RS232 null-modem serial connection cable with 9-pole SubD connector for the PC and 3-pole connector for the COM AUX port of the instrument.

CP27: Serial connection cable with USB connector for the PC and 3-pole connector for the COM AUX port of the instrument. The cable has a builtin USB/RS232 converter and connects the transmitter directly to the USB port of the PC.

Pitot tubes: see list and dimensions at next page.

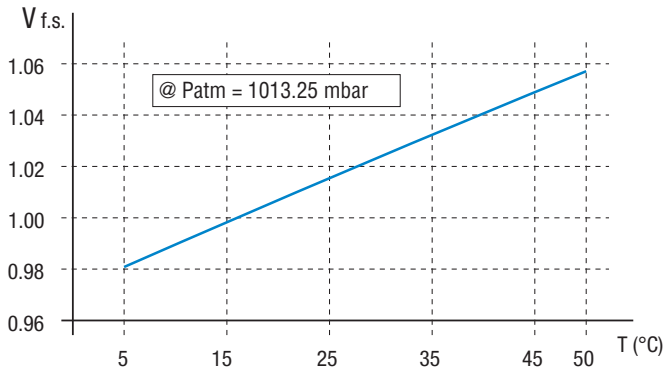

Change of the full scale speed with the temperature at constant barometric pressure

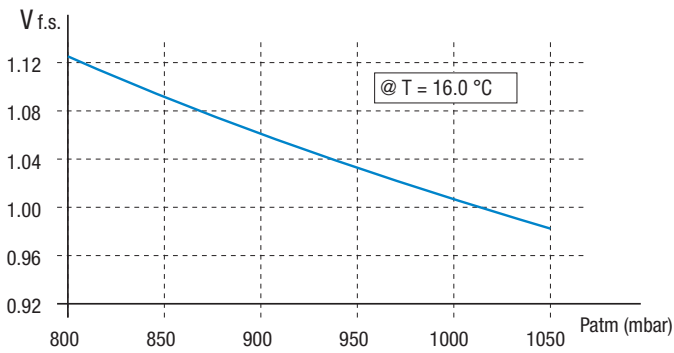

Change of the full scale speed with the barometric pressure at constant temperature

In the SR models, the serial command "CS nnnn" allows to associate to the full scale of the analog output a speed value chosen by the user, even different from the maximum value actually measurable by the transmitter.

AP3719 duct probe

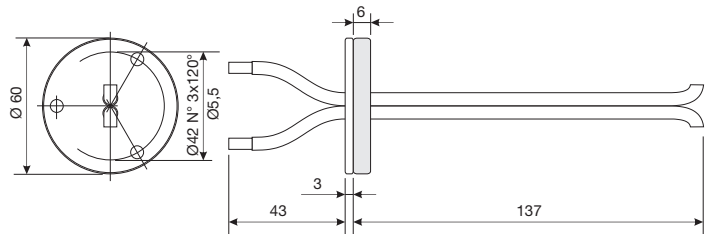

AP3721 duct probe:

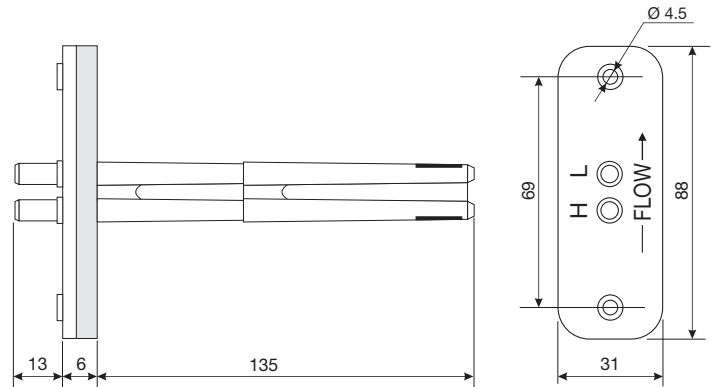

HD404T 1P - G - AZ - L - SR

SR = with square root output
(not available for type D versions)

L = with LCD display

AZ = with auto-zero circuit

D = differential pressure -f.s...+f.s.

G = relative pressure with reference to the atmosphere 0...+f.s.

Nominal full scale (f.s.):

1P = 100Pa, 2P = 250Pa, 3P = 500Pa, 4P = 1000Pa

1M = 10mmH₂O, 2M = 25mmH₂O, 3M = 50mmH₂O, 4M = 100mmH₂O

1I = 0.4inchH₂O, 2I = 0.8inchH₂O, 3I = 2inchH₂O, 4I = 4inchH₂O



HD404T3PD

PITOT TUBES

Stainless steel Pitot tubes for air speed measurement, supplied with silicone tube \varnothing 6mm external, \varnothing 4mm internal, length 2m.

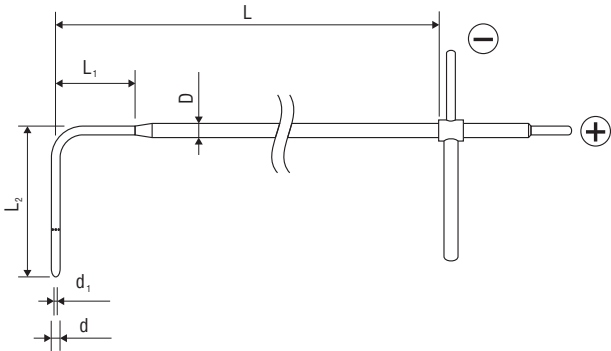

	d mm	d ₁ mm	D mm	L mm	L ₁ mm	L ₂ mm	Temp. °C	Material
T1-300	3	1	6	300	30	72	0...600°C	AISI 316
T2-400	5	2	8	400	45	120		
T2-600	5	2	8	600	45	120		
T3-500	8	3,2	8	500	---	192		
T3-800	8	3,2	8	800	---	192		
T4-500	10	4,0	10	500	---	240		
T4-800	10	4,0	10	800	---	240		
T4-1000	10	4,0	10	1000	---	240		

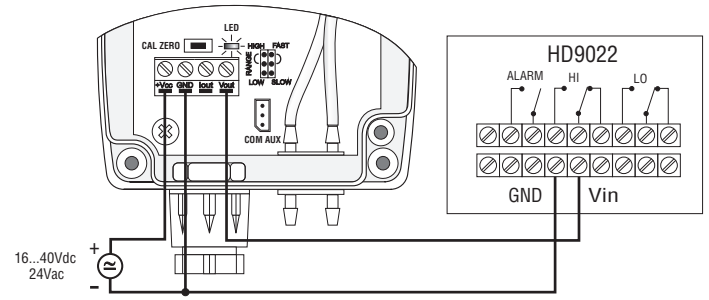

Voltage output 0...10Vdc

Examples of connection with HD9022 indicator regulator

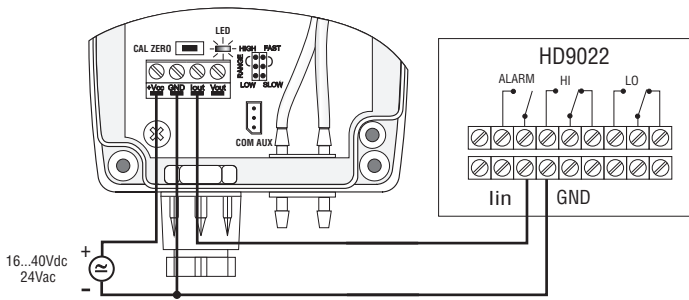

Current output 4...20mA

Pressure

