



**HD3604T..., HD36V4T...
RELATIVE PRESSURE TRANSMITTERS**

HD3604T... and HD36V4T... are pressure transmitters with microprocessor and current (4...20mA) or voltage (0...5V, 1...5V or 0...10V) output, respectively. The sensor, piezoresistive, is insulated and allows gas and liquid pressure measurement over a wide range of temperatures.

The measured pressure is relative to atmosphere. The different models cover the scales from 100mbar to 600bar.

The case is in stainless steel 20mm diam. and encloses sensor and electronics: in order to connect it to a pressurized system, it is supplied with a 1/4" BSP threaded connection with a 22mm hex fastening ring.

For electrical connections a male connector DIN 43650A is used.

The connector is fitted with a three or four pole free female socket with fairlead (according to the models).

All transmitters are factory calibrated at three points. The use of a microprocessor circuit allows memorizing the sensor response curve and correcting any possible non linearity.

No calibration is requested to the user. The pressure transmitters HD3604T... and HD36V4T... can be connected to the single input configurable controller HD9022, to the dual input DO9404 or to the led display HD 2601V.1.

Technical characteristics		Notes
Output signal	4 ...20mA	HD3604TxBG models
	0 ...5V	HD36V4TxBG1 models
	1 ...5V	HD36V4TxBG2 models
	0 ...10V	HD36V4TxBG3 models
Full scale pressure	100, 200, 400, 600 mbar 1, 2.5 bar 4, 6, 10, 16, 25, 40, 60, 100, 160, 250, 400 and 600 bar relative	
Overpressure limit	Twice the nominal full scale value	
Sensor	Piezoresistive	
Surface in contact with fluid	Steel 17-4PH	
Fluid in contact with membrane	Gas or liquid	
Operating temperature	-40 ... +125°C	-20 ... +80°C for 100 and 200 mbar f.s.
Power supply voltage	10...30Vdc	
	15...30Vdc	HD36V4TxBG3 models with 0...10Vdc output
Absorption	< 4mA	In the models with voltage output
Accuracy	≤ ±0.25%F.S.	
Temperature effects	±1% span ±1% offset	For a variation of 100°C
Mechanical stability	< 0.1%F.S.	After 10 ⁶ cycles 0...f.s.
Response time	5ms	
Connection to the system under pressure	1/4" BSP male	
Electric connection	Male connector 3 or 4 poles DIN 43650A + female connector DIN 46350A	
Dimensions	Ø 20mm	Ø 30mm in the models up to 2.5 bar
	L=100mm	Case included. L=105mm in the models 400 and 600 mbar, 1 bar
Case material	Stainless steel AISI 304	
Weight	100gr	220g in the models 400 and 600 mbar, 1 bar
Load resistance	$R_{Lmax} = 636\Omega$ a 24Vdc $R_{Lmax} = \frac{(Vdc - 10)}{22mA}$	For the models with current output 4...20mA HD3604T...
	$R_L \geq 10k\Omega$	For the models with volt- age output HD36V4T ...
Protection degree	IP65	With connector correctly engaged.

Pressure

Installation and connections

The HD3604T... and HD36V4T... transmitters can be installed in any position.

Make the electrical connection to the free female connector as indicated in the diagrams of the following table.

Transmitter model	Connection diagram of the transmitter pin (front view)	Notes
HD3604TxBG		If the connection cable is shielded, connect the shield to pin
HD36V4TxBG...		Use a shielded connection cable and connect the shield to the pin

In the models with a 4...20mA current output, use the following connections:

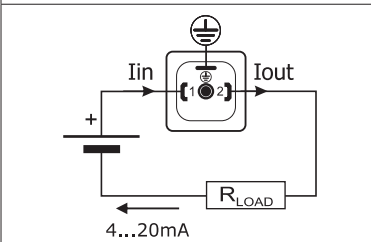

HD3604TxBG

In the models with a voltage output, use the following connection:

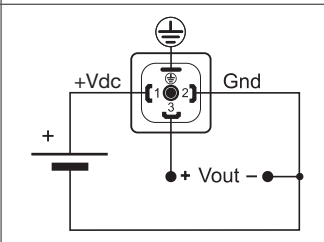

HD36V4TxBG...

DIN 43650A connector

To make the electrical connections you need to open the female connector.

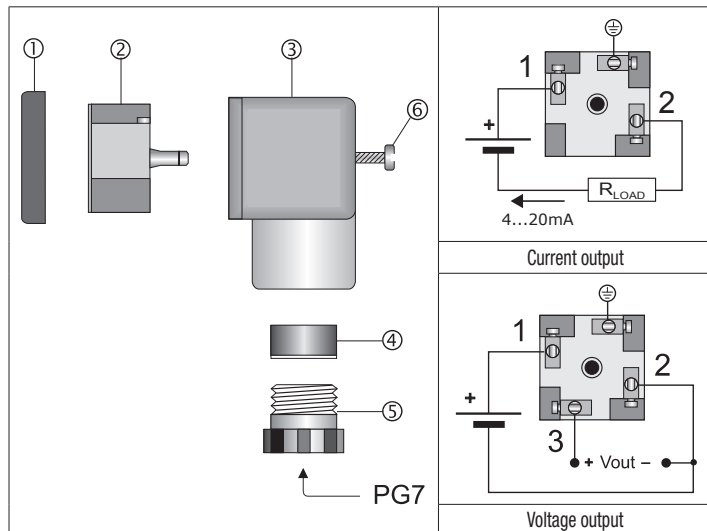

Remove the gasket ①. Unscrew the fairlead ⑤ and take off the gasket ④. Use a screwdriver to pry and take off the connecting terminal ②. Make the connections as shown in the figure: if present, the shielded cable braid must be connected to the earth terminal. Once the connections are made, close the connector.

Transmitter calibration

The transmitters are calibrated at three points; no calibration is requested to the user.

Warnings

The pressure transmitter has a male threaded 1/4" BSP. During installation, take special care to the pressure resistance of the junction. Use any appropriate seals.

Great attention must be placed in the installation of transmitters in the pressure vessel or piping. Attention must be paid to the choice of full scale flow rate for an error, in addition to permanently damage the transmitter, can cause personal injuries and property also severe. Always insert, before the first transmitter, a key stop and make sure that the plant will not occur abnormal and unexpected peaks or surges of fluid under pressure.

Mechanical Dimensions

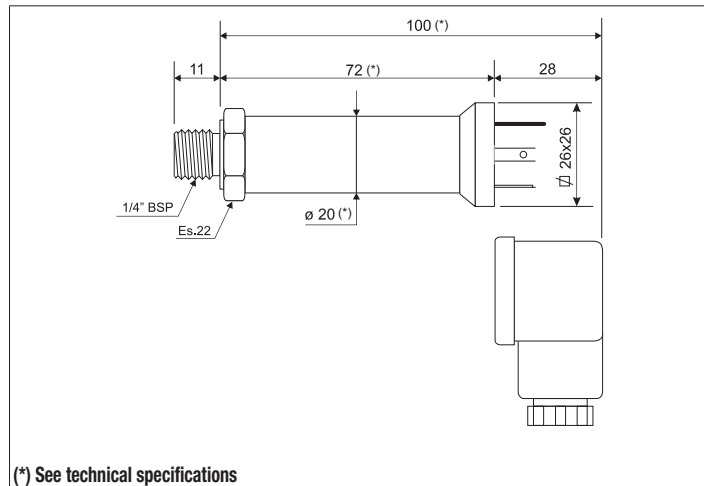

(*) See technical specifications

Examples of connections with the HD9022 and DO9404 indicators/regulators

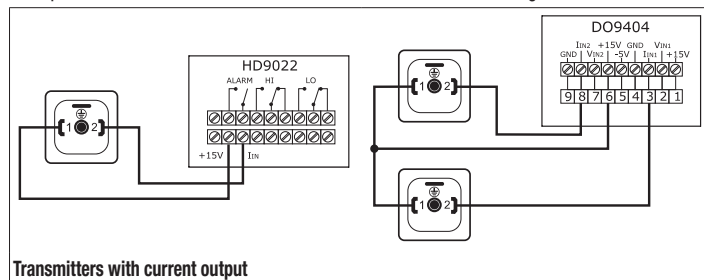

Transmitters with current output

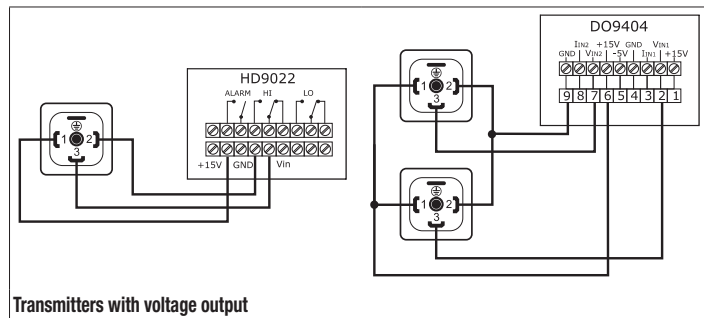

Transmitters with voltage output

Order codes:

HD36 X 4T X BG X

No symbol = 4...20mA current analog output
1 = Voltage analog output 0...5Vdc
2 = Voltage analog output 1...5Vdc
3 = Voltage analog output 0...10Vdc

MB = mbar
B = Bar
G = Gauge (relative pressure)

Nominal full scale (bar)
 100 - 200 - 400 - 600 mbar - 1 - 2,5 relative bar
 4 - 6 - 10 - 16 - 25 - 40 - 60 - 100 - 160 - 200 - 250
 400 - 600 - relative bar

0 = Analog output 4...20mA
V = Voltage analog output