



HD52.3D 2 AXES ULTRASONIC ANEMOMETERS

2 axes ultrasonic Anemometers series HD 52.3D....

The instruments of the series HD52.3D... are 2 axes ultrasonic static anemometers for measuring:

- Wind speed and direction, U-V Cartesian components of wind speed,
- Relative Humidity and Temperature (**optional, code '17'**),
- Diffuse Solar Radiation (**optional, code 'P'**),
- Barometric pressure (**optional, code '4'**).

All models are equipped with compass.

RS232, RS485, RS422 and SDI-12 serial interfaces are available with **NMEA, MODBUS-RTU** and **SDI-12** communication protocols.

All versions have two analogical outputs, both for wind speed and for direction, factory configurable among 4÷20mA (**standard**), 0÷1V, 0÷5V, 0÷10V (**to be specified when ordering**).

Optionally available, (ACCREDIA) **ILAC-MRA** traceable factory calibration.

Advantages:

- The absence of moving parts minimizes maintenance;
- High sensitivity for detecting very low speeds, which are not detectable by traditional methods;
- The low power of the instrument allows installation in remote sites, with power from solar panel and battery;
- The heating option '**R**' prevents the accumulation of snow and ice from forming, allowing accurate measurements in all environmental conditions;
- Fast and easy installation (on 40mm diameter pole, optional installation kit HD2004.20), alignment facilitated by built-in compass;
- The available measurement options join together in one single, compact and lightweight instrument, the main variables of interest in weather stations;
- MODBUS-RTU output allows instrument networking.

Typical applications:

- Weather stations
- Environmental monitoring
- Agriculture
- Sports facility
- Marine and Harbour applications
- Airports
- HVAC
- Construction
- Renewable energy
- Building automation

Technical specifications:

Wind speed	
Employed sensor type	Ultrasonic
Measuring Range	0...60 m/s
Resolution	0.01 m/s
Accuracy	Whichever is greater $\pm 0,2$ m/s or $\pm 2\%$, (0...35 m/s) $\pm 3\%$ (> 35 m/s)
Wind direction	
Employed sensor type	Ultrasonic
Measuring Range	0...360°
Resolution	0.1°
Accuracy	$\pm 2^\circ$ RMSE from 1.0 m/s
Compass	
Employed sensor type	Magnetic
Measuring Range	0...360°
Resolution	0.1°
Accuracy	$\pm 1^\circ$
Air temperature (option 17 is requested)	
Employed sensor type	Pt100
Measuring Range	-40...+60 °C
Resolution	0.1 °C
Accuracy	$\pm 0,15^\circ\text{C} \pm 0,1\%$ of the measure
Relative Humidity (option 17 is requested)	
Employed sensor type	Capacitive
Measuring Range	0...100%RH
Resolution	0.1%
Accuracy (@ T = 15...35 °C)	$\pm 1,5\%$ UR (0..90%RH), $\pm 2\%$ RH (remaining field)
Accuracy (@ T = -40...+60 °C)	$\pm (1,5 + 1,5\%$ of the measure)%RH
Barometric Pressure (option 4 is requested)	
Principle	Piezoresistive
Measuring Range	600...1100 hPa
Resolution	0.1 hPa
Accuracy	$\pm 0,5$ hPa @ 20°C
Solar Radiation (option P is requested)	
Employed sensor type	Thermopile
Measuring Range	0...2000 W/m ²
Resolution	1 W/m ²
Accuracy	2 nd class Pyranometer
General features	
Power supply	10...30 Vdc
Power Consumption	26mA @ 12Vdc without heater, 6W with heater
Serial Outputs	RS232, RS485, RS422 and SDI-12
Communication Protocols	NMEA, MODBUS-RTU, SDI-12
Analog Outputs	2 analog outputs for wind speed and direction. Output type to be specified when ordering among 4...20mA (standard), 0...1V, 0...5V and 0...10V (option 0...10V requires power supply 15...30Vdc)
Electrical connection	male connector M23 19 poles
Working temperature	-40...+60 °C
Dimensions	H=179mm, Ø=150mm (HD52.3D, HD52.3D4) H=200mm, Ø=150mm (HD52.3DP, HD52.3DP4) H=336mm, Ø=150mm (HD52.3D17, HD52.3D147) H=357mm, Ø=150mm (HD52.3DP17, HD52.3DP147)
Weight	about 1 Kg (full version, HD52.3DP147)
Housing	Plastic material: LURAN®S (ASA) Metallic parts made of AISI 316
Protection degree	IP66

DIMENSIONS (mm)

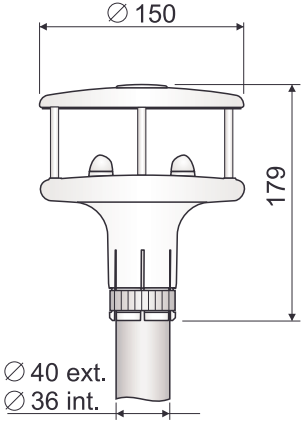
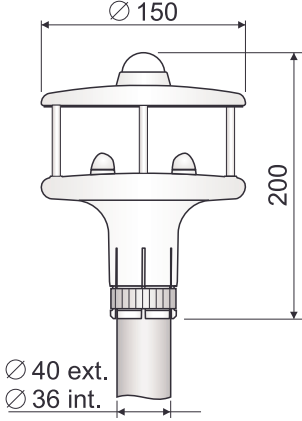
 <p>HD 52.3D Wind speed and direction.</p> <p>HD 52.3D4 Wind speed, wind direction and barometric pressure.</p>	 <p>HD 52.3DP Wind speed, wind direction and solar radiation.</p> <p>HD 52.3DP4 Wind speed, wind direction, solar radiation and barometric pressure.</p>
---	---

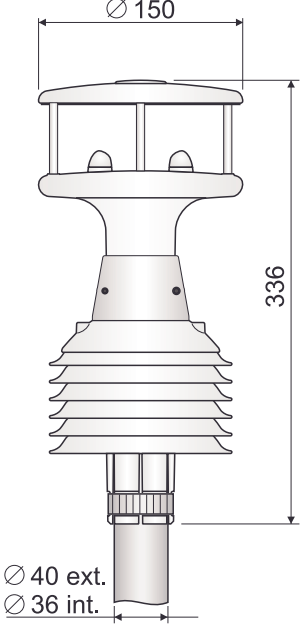
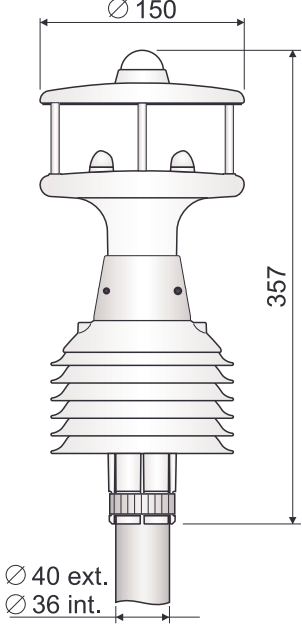
 <p>HD 52.3D17 Wind speed, wind direction, temperature and relative humidity.</p> <p>HD 52.3D147 Wind speed, wind direction, temperature, relative humidity and barometric pressure.</p>	 <p>HD 52.3DP17 Wind speed and direction, solar radiation, temperature, relative humidity.</p> <p>HD 52.3DP147 Wind speed, wind direction, solar radiation, temperature, relative humidity and barometric pressure.</p>
--	--

ORDERING CODES

HD 52.3D

R = heater option
Blank = not heated

P = solar radiation option (pyranometer)
4 = barometric pressure option
17 = relative humidity and temperature option
P4 = solar radiation and barometric pressure option
P17 = solar radiation, relative humidity and temperature option
147 = barometric pressure, relative humidity and temperature option
P147 = solar radiation, barometric pressure, relative humidity and temperature option
No characters = basic version: **wind speed and direction**

Analog outputs for wind speed and direction: 4...20mA standard; to be requested: 0...1V, 0...5V or 0...10V (**0...10V option requires power supply 15...30Vdc**).

HD52.3D...: 2 axes ultrasonic static anemometers for the measure of wind speed and direction, U-V Cartesian components of wind speed, relative humidity and temperature (**optional**), diffuse solar radiation (**optional**) and barometric pressure (**optional**). A compass is supplied. RS232, RS485, RS422 and SDI-12 serial outputs, **NMEA**, **MODBUS-RTU** and **SDI-12** communication protocols. Two analogical outputs, for wind speed and direction, factory configurable among 4÷20mA (**standard**), 0÷1V, 0÷5V or 0÷10V (**to be specified when ordering**). Heater option is available. Power supply: 10...30Vdc (15...30Vdc for 0÷10V analog outputs). Installation on a pole: external Ø 40mm and internal Ø 36mm. Input with M23 19-pin male connector and M23 19-pin female flying connector. **Optional 5m or 10m cable with a connector on one side and open wires on the other.**



Air speed



HD 2004.20

ACCESSORIES

HD52.3D-S: Further copy of CD-ROM with HD52.3D-S software for PC connection, instrument configuration and monitor. For Windows® operating systems.

RS 52 : Serial connection cable with built-in USB/RS232 converter. USB connector for the PC and screw terminals on the instrument side. The cable is used to configure the instrument before the installation. Length 1.5 m.

CP52.5: Connection cable with M23 19-pin female flying connector on one side, free wires on the other. 5m long.

CP52.10: Connection cable with M23 19-pin female flying connector on one side, free wires on the other. 10m long.

CP52.15: Connection cable with M23 19-pin female flying connector on one side, free wires on the other. 15m long.

CP52.20: Connection cable with M23 19-pin female flying connector on one side, free wires on the other. 20m long.

CP52.C: Further M23 19-pin female flying connector.

HD2004.20: Tripod kit for installing anemometers on a flat base. Height 3m.

HD2004.22: 1200x530x34mm Solar panel mounting kit to a Ø 40÷50mm pole. AISI 304 stainless steel.



HD 32MT.1

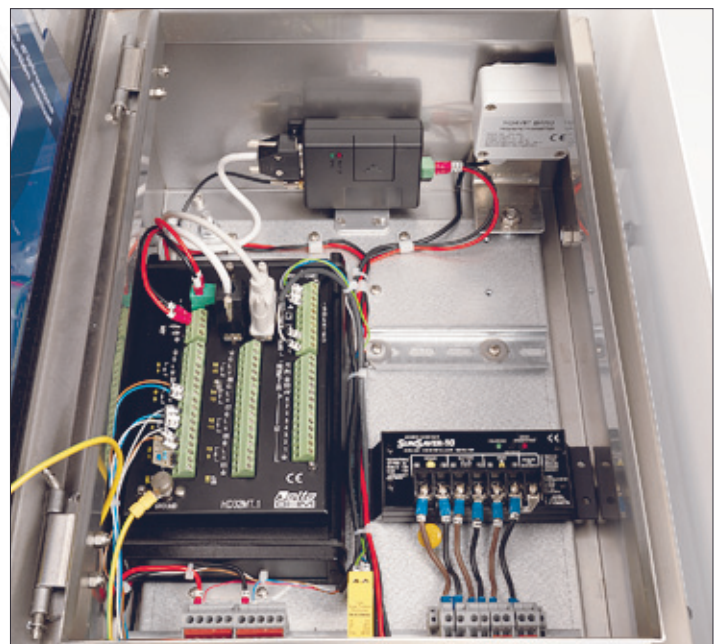

HD 32.35FP

HD2004.30: 80W monocrystalline solar panel. Dimensions 1200 x 530 x 34 mm. Model MD5000080 – CS EVOLUTION.

HD32.35: Outdoor-box for complete weather station acquisition system. **Material: AISI 304 stainless steel.** Screen to protect the box from solar radiations. Powder-coated, anodized aluminium white colour. Double lock, one with a key. Dimensions: 450 x 300 x 210 mm. Protection degree: IP66. Equipped with the accessories to mounting on a mast diameter 36 ÷ 52 mm. Provided for 100÷240Vac mains power supply, includes: HD32MT.1 datalogger, power supply unit AC / DC with battery charger, rechargeable 12V battery, surge protection, breakers, power distribution terminals and connectors for connection to external sensors.

HD32.35FP: Outdoor-box for complete weather stations acquisition system. **Material: AISI 304 stainless steel.** Screen to protect the box from solar radiations. Powder-coated, anodized aluminium white colour. Double lock, one with a key. Dimensions: 450 x 300 x 210 mm. Protection degree: IP66. Equipped with the accessories to mounting on a mast diameter 36 ÷ 52 mm. For power supply by solar panel, includes: HD32MT.1 logger, solar panel charge controller, and power distribution terminal block connectors for connection to external sensors.

HD32.36: Outdoor-box for complete weather stations acquisition system. **Material: Polyester reinforced with hot-moulding Fiberglass.** Screen to protect the box from solar radiations. Powder-coated, anodized aluminium. White colour. Key lock. Dimensions: 415 x 310 x 170 mm. Protection degree: IP66. Equipped with the accessories to mounting on a mast diameter 36 ÷ 52 mm. Provided for 100÷240Vac mains power supply, includes: HD32MT.1 datalogger, power supply unit AC / DC with battery charger, rechargeable 12V battery, surge protection, breakers, power distribution terminals and connectors for connection to external sensors.

HD32.36FP: Outdoor-box for complete weather stations acquisition system. **Material: Polyester reinforced with hot-moulding Fiberglass.** Screen to protect the box from solar radiations. Powder-coated, anodized aluminium. White colour. Key lock. Dimensions: 415 x 310 x 170 mm. Protection degree: IP66. Equipped with the accessories to mounting on a mast diameter 36 ÷ 52 mm. For power supply by solar panel, includes: HD32MT.1 logger, solar panel charge controller, and power distribution terminal block connectors for connection to external sensors.

Air speed

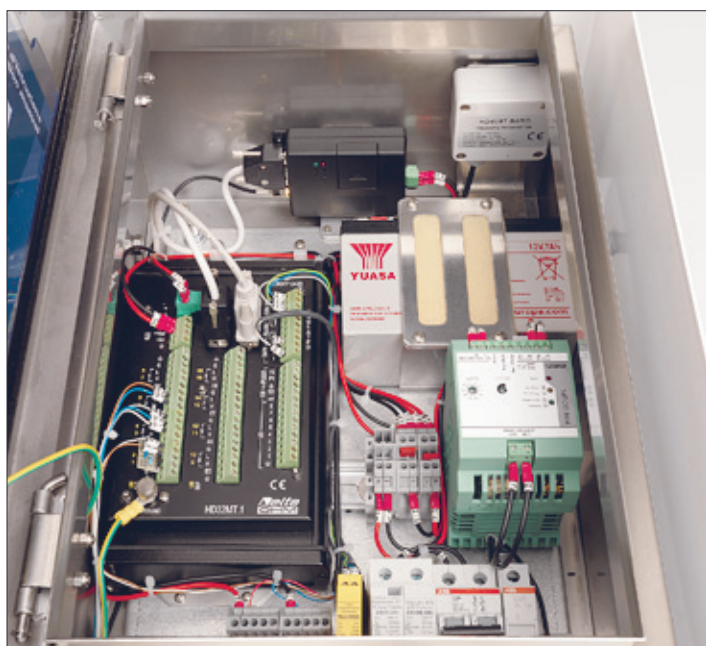

HD 32.35