

The Delta Ohm sound level meters perform spectral corrections to the measures to ensure tolerances in accordance with the IEC61672 class 1 in every situation.

The microphone unit **HDWME** provides an optimized frequency response for "free field". Since the microphone is installed in a vertical position, the frequency response is flat for the sound waves coming from above, such as those of aircraft overflights. To correct the HDWME frequency response for the presence of the windscreen, the proper parameter of the sound level meter has to be set as follows:

Menu >> Calibration >> Screen Correction >> WME.

The frequency response of the microphone to noise coming from the surrounding ground is very different from that for "free field". By setting the parameter:

Menu >> Calibration >> Microphone Response >> RI

the sound level meter applies the necessary spectral correction for measurements of noise coming from the ground in accordance with specifications of class 1 according to IEC 61672 (and IEC 60651) and ANSI standards.

The easiness of disassembly and reassembly of the unit allows to perform periodic testing of the electro-acoustic characteristics the same way as a standard measurement microphone, using a standard calibrator for 1/2" microphone.

When calibration is complete, refit the protections according to the explanations under Assembly.

The unit consists of a central body and the following parts:

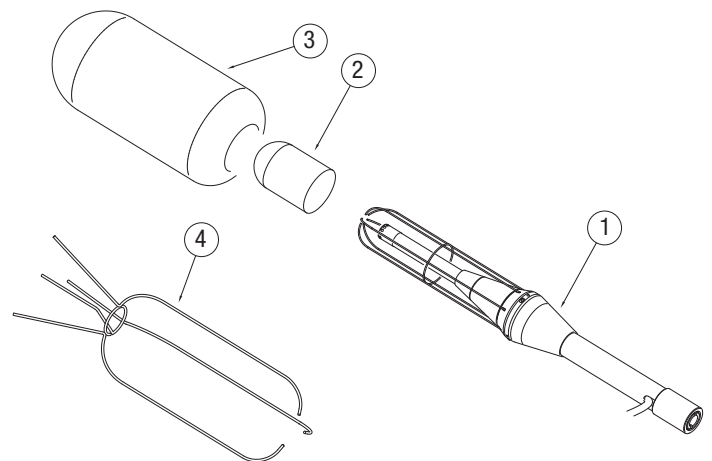

- HDSAV3: windscreen (3)
- HDWME1: birdspike (4)
- HDWME2: rainshield (2)
- HDWME3: stainless steel holder (1)

Microphone capsule:

- UC52: 1/2" free field type 2 condenser microphone, prepolarized (0V) for HD2010UC and HD2010UC/A class 2
- UC52/1: 1/2" free field type 1 condenser microphone, prepolarized (0V) for HD2010UC and HD2010UC/A class 1
- MC21E: 1/2" free field type 1 condenser microphone, prepolarized (0V) for HD2110L

Microphone preamplifier:

- **HD2010PNE2W:** heated preamplifier for pre-polarized microphones UC52 and UC52/1 with integrated extension cable L=5mt (10mt on request). For HD2010UC and HD2010UC/A sound level meters.
- **HD2110PEWL:** heated preamplifier for pre-polarized microphones MC21E with integrated extension cable L=5mt (10, 20, 50mt on request). For HD2110L sound level meters.



HD WME MICROPHONE OUTDOOR PROTECTION

Applications

- Stationary and mobile noise control
- Long-term outdoor measurements

Features

- Microphone protection from wind and rain
- Stainless Anti-bird spikes
- Heated preamplifier
- Frequency response according to IEC 61672:2002-5 (and IEC 60651:2001-10) and ANSI S1.4:1983, both for airport and community noise
- Compatible with standard 1/2" microphone sound calibrator

Description

The HDWME microphone unit is suitable for long term outdoor monitoring, even in a fixed unattended location. The unit is adequately protected from rain and wind and the heated preamplifier provides stability of acoustic parameters over time and allows to make measurements over a wide range of environmental conditions.

The Delta Ohm sound level meter preamplifier matched with the outdoor microphone unit is equipped with a circuit for electrical calibration of the preamplifier - microphone chain, a technique that uses a charge distribution.

The free field frequency response, meets the specifications of class 1 according to IEC 61672 (and IEC60651) and was certified by I.N.R.I.M. (Certificate of conformity No. 10-0126-02 of 04.29.2010). **The microphone unit HDWME must always be positioned vertically** to allow the anti-rain to perform its function and can be used both to detect the noise at 0° and 90° directions.

Calibration

To perform the calibration, the 1/2" standard microphone must be made available by removing the wind and rain protections (see Section Disassembly). Before performing the electrical or acoustical tests you need to disable the spectral corrections of the sound level meter by setting the following parameters:

- Menu >> Calibration >> Microphone Response >> FF
- Menu >> Calibration >> Screen Correcton >> OFF

For electrical testing, you can connect a generator of electrical signals to the preamplifier unit HDWME via a capacitive adapter which replaces the microphone and can be supplied by Delta Ohm on request from the calibration laboratory. For additional details and specifications of *capacitive adapter*, please see the document "Periodic calibration according to IEC61672-3 of Delta Ohm sound level meters" available on HYPERLINK "<http://www.deltaohm.com>" website (Home >> Support >> Documentation).

Disassembly

To completely disassemble the unit, a 1.5mm male hex key and a 14mm wrench are needed. To separate all components of the unit, proceed as follows; to extract the group-preamplifier microphone capsule to calibrate, start from step 3:

1. Remove the bird spike by loosening the three hex head screws at the base of the windscreen:

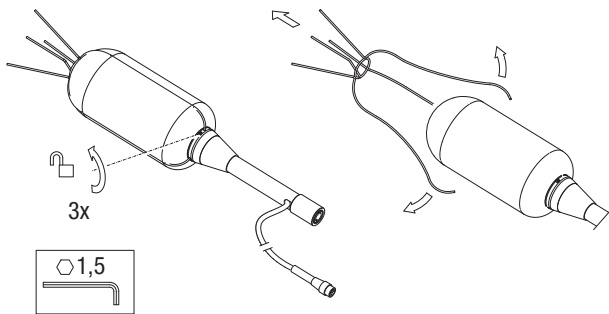

2. Pull up the windscreen HDSAV3 and rain protection HDWME2.

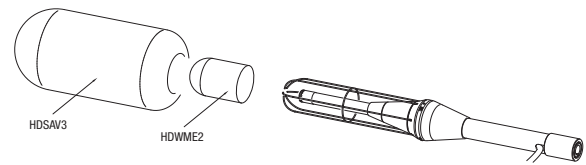

3. Unscrew the terminal placed at the lower end of the stem (A).

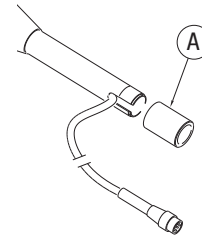

4. Unscrew the stem (B) and disconnect the cable connected to the preamplifier.

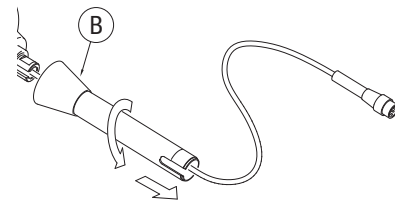

5. Unscrew the lock nut of the preamplifier (C) using, if necessary, a 14mm wrench. Be careful not to twist the preamplifier cable.

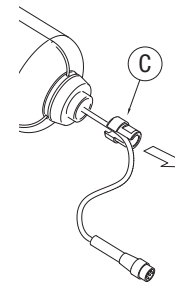

6. Remove the preamplifier (D) by pulling slowly down. At this point the microphone is accessible and you can proceed with calibration.

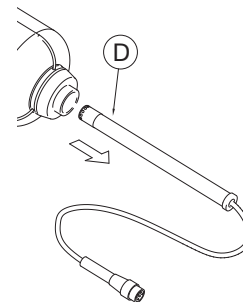

For details on calibration, see the manual attached to the sound level meter

7. For assembly of the protection, proceed as specified in the following paragraph.

Assembly

To assemble the unit, a 1.5mm male hex key and a 14mm wrench are needed. To assemble the protection completely, start from Step 1. If you need only to assemble the preamplifier with the microphone after calibration, from Step 4.

1. Fit the rain shield HDWME2 on the metal grid support.

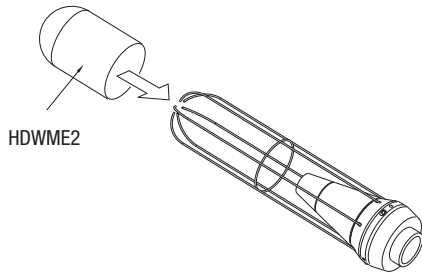

2. Insert the wind screen HDSAV3.

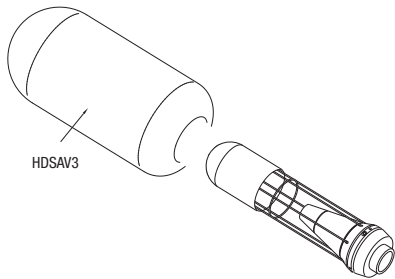

3. Apply the bird spikes and secure it using the three hex head screws located on the support at the base of the windscreen.

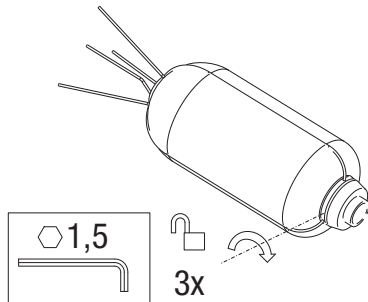

4. Insert the preamplifier (A) into the support pushing slowly upward until its limit position.

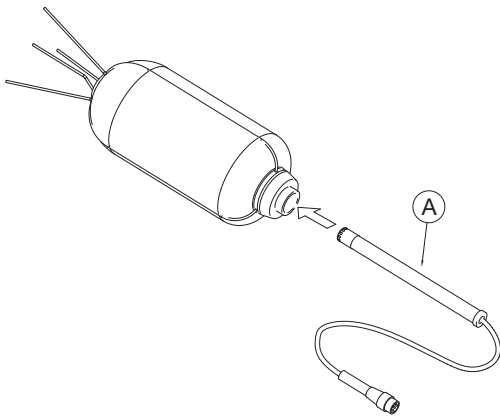

5. Screw the gland (B) using, if necessary, a 14mm wrench. Be careful not to twist the preamplifier cable.

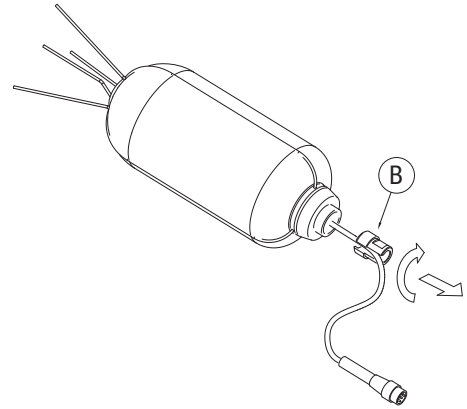

6. Insert the cable connected to the preamplifier through the stem (C) and screw the stem to the support.

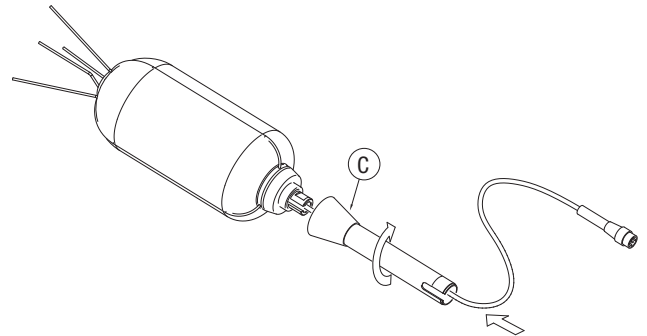

7. Screw the terminal placed at the lower end of the stem (D) releasing the cable laterally.

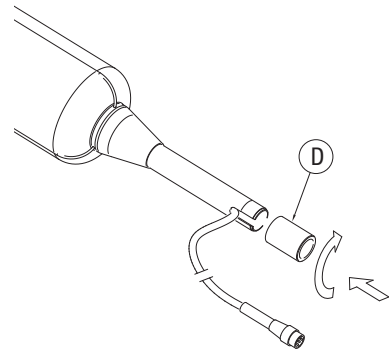

8. To secure protection for outdoor use you can use the threaded end (D) or you can apply the fitting (E) on a tripod. The terminal (E) has two threads, 1/2" and 1/4".

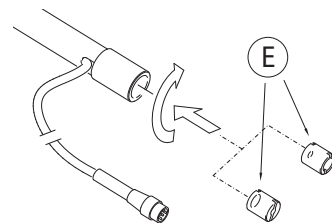

Maintenance

To avoid permanent alteration of the frequency response and consequently a degradation of specifics so as to exit the class 1 tolerance limits, is necessary to prevent accumulation of dust and dirt particles on the microphone membrane. The microphone capsules must be periodically cleaned. **This operation is usually performed during the periodic calibration** and can be performed at Delta Ohm or at an accredited laboratory for calibration of measurement microphones. **It is recommended to calibrate the unit yearly.**

The removal of the protective grid of the microphone must be performed by qualified personnel. The dirt on the membrane can be cleaned with a soft cloth by working very carefully so as not to damage it. Avoid using the unit in the presence of vapors containing oils, conductive or corrosive substances. Condensation on the membrane should be avoided because it significantly modifies the acoustic response, causes corrosion and contributes substantially to the formation of residues that are hard to remove.

When the unit is used to make measurements, the sound level meter power and the preamplifier heating prevent condensation on the membrane. For this reason, when the unit is not used, it should be stored in a dry place.

ORDERING CODES

HDWME: Outdoor microphone protection for HD2110L, HD2010UC and HD2010UC/A. (for older models contact your local distributor)

Includes:

- Stainless steel preamplifier support HDWME3
- Windshield HDSAV3
- Rain shield HDWME2
- Anti bird-spikes HDWME1

HD2010PNE2W: heated preamplifier for pre-polarized microphones UC52 and UC52/1 with integrated extension cable L=5mt (10mt on request) For HD2010UC and HD2010UC/A sound level meters.

HD2110PEWL: heated preamplifier for pre-polarized microphones MC21E with integrated extension cable L=5mt (10, 20, 50mt on request). For HD2110L sound level meters.

UC52: ½" free field type 2 condenser microphone, prepolarized (0V) for HD2010UC and HD2010UC/A class 2

UC52/1: ½" free field type 1 condenser microphone, prepolarized (0V) for HD2010UC and HD2010UC/A class 1

MC21E: ½" free field type 1 condenser microphone, prepolarized (0V) for HD2110L

Standard preamplifier can be replaced by *heated* version that can work in conjunction with HDWME outdoor protection:

HD2010.OR option "Heated preamplifier": replacement of the standard preamplifier HD2010PNE2 with the heated version HD2010PNE2W. The heated preamplifier is combinable with the microphone outdoor protection HDWME and is equipped with CTC device for electrical calibration and 5m integrated extension cable (10m on request). For HD2010UC and HD2010UC/A sound level meters.

HD2110.OR option "Heated preamplifier": replacement of the standard preamplifier HD2110PEL with the heated version HD2110PEWL. The heated preamplifier is combinable with the microphone outdoor protection HDWME and is equipped with CTC device for electrical calibration and 5m integrated extension cable (other lengths on request). **This option is available only in conjunction with MC21E or standard pre-polarized microphones. It's not compatible with option HD2110.OP.** For HD2110L sound level meters.

Example of a complete microphone unit:

Outdoor microphone unit for HD2110L. Includes:

- Stainless steel preamplifier support HDWME3
- Windscreen HDSAV3
- Rainshield HDWME2
- Anti-bird spikes HDWME1
- Heated preamplifier with 5m cable HD2110PEWL
- ½" pre-polarized condenser microphone MC21E

Accessories

HDWME1: Anti-bird spikes for outdoor protection HDWME.

HDWME2: Rain shield for outdoor protection HDWME.

HDWME3: stainless steel housing for the preamplifier and support for rain shield of outdoor protection HDWME.

HDSAV3: Windscreen for outdoor protection HDWME.

Specifications

Microphone MC21E

Type	½" standard condenser
Class	1
Polarization voltage	0V
Frequency response	3.15Hz – 20 kHz
Sensitivity	50 mV/Pa
Maximum sound pressure level (3% THD at 1kHz)	146 dB

Microphone UC52/1

Type	½" standard condenser
Class	1
Polarization voltage	0V
Frequency response	20Hz – 16 kHz
Sensitivity	22.5 mV/Pa
Maximum sound pressure level (3% THD at 1kHz)	146 dB

Microphone UC52

Type	½" standard condenser
Class	2
Polarization voltage	0V
Frequency response	22.5Hz – 10 kHz
Sensitivity	22.5 mV/Pa
Maximum sound pressure level (3% THD at 1kHz)	146 dB

Preamplifier

Power supply	± 6V
Power consumption	5 mA
Heater	35 mA @ 6V
Output impedance	50 Ω

Operating conditions

Temperature	-25 ... +70 °C
Relative humidity	< 100% without condensation

Mechanical

Dimensions (Ø x L) complete with Anti-bird spikes	90 x 470 mm
Weight	600 g
Thread for type MC21E microphone	11.7 mm 60 UNS
Thread for type UC52 microphone	M11.6 x 0.4
Thread for the support of the unit	M18 x 1, ½ W, ¼ W
Cable lengths	5m (other lengths available on request)
Connector	DIN 8-pole